

PondMAX[®]

FOR GARDENS THAT GO THE EXTRA YARD

SUBMERSIBLE WATER PUMP

INSTRUCTION MANUAL



EVOLV
SERIES

VERSION
NOV 2023

www.pondmax.com.au

MODEL
02EV200 - EV7200
02EV225 - EV9200
02EV250 - EV11200
02EV275 - EV13600

PondMAX**evolll**
SERIES

WELCOME TO THE WORLD OF PONDMAX™.
 YOU MADE THE **RIGHT** CHOICE INVESTING IN THIS
QUALITY PRODUCT. THANK YOU AND **ENJOY.**

BEFORE USING THIS PRODUCT, PLEASE READ THESE INSTRUCTIONS OF USE CAREFULLY AND MAKE YOURSELF FULLY FAMILIAR WITH THE UNIT. PLEASE KEEP THESE INSTRUCTIONS IN A SAFE PLACE FOR FUTURE REFERENCE.

TECHNICAL SPECIFICATIONS

DESCRIPTION	EV7200	EV9200	EV11200	EV13600
MAXIMUM WATER FLOW(L/H)	7200	9300	11200	13600
MAXIMUM HEAD (M)	5.5	6.0	6.5	7.0
POWER CONSUMPTION* (W)	85	105	160	230
VOLTS (V)	220 - 240	220 - 240	220 - 240	220 - 240
FREQUENCY (HZ) AC	50	50	50	50
IP RATING	IPX8	IPX8	IPX8	IPX8
INLET Ø BSP THREAD	1½IN / 40MM	1½IN / 40MM	1½IN / 40MM	1½IN / 40MM
OUTLET Ø BSP THREAD (MALE)	1½IN / 40MM	1½IN / 40MM	1½IN / 40MM	1½IN / 40MM
THREADED BALL JOINT INCLUDED	Yes	Yes	Yes	Yes
THREADED BALL JOINT OUTLET - 1 1/2" MALE BSP	Yes	Yes	Yes	Yes
CABLE LENGTH (M)	10	10	10	10
RECOMMENDED TUBING SIZE (MM) ID	40	40	50	75

* SUBJECT TO VARIATION ACCORDING TO LOAD

OTHER MODELS AVAILABLE IN THE EVOII RANGE	EV1900	EV2900	EV3900	EV4900	EV1910-DC	EV2910-DC	EV3910-DC	EV4910-DC
MAXIMUM WATER FLOW (L/H)	1800	3000	4000	4900	1800	2800	3800	4600
MAXIMUM HEAD (M)	2.4	3.4	3.8	5.0	2.1	2.95	4.6	5.1
VOLTS (V)	240	240	240	240	12V - DC	12V - DC	12V - DC	12V - DC
SUITABLE FOR SOLAR	NO	NO	NO	NO	Yes	Yes	Yes	Yes

SUBMERSIBLE WATER PUMPS

DESIGN HIGHLIGHTS

The PondMAX Evoll Submersible Pumps have been manufactured with advanced technology to provide you with the best quality pumps for your pond or water feature. Visit our website to view our range of pond filtration, outdoor/ underwater lighting, water treatments and general accessories.

- **Variable Frequency Motor Technology** – Extra high speed rotations of impellor.
- **Open Vane Impellor Design** – Handles large particles size up to 4mm soft sediment.
- **Long life Impellor Design** – Ceramic shaft is wear resistant and self-lubricated by water
- **High Head Pressure** – Due to extra high speed rotations of impellor.
- **Energy Efficient** – Exceptional low power consumption to high water flow conversion.
- **Eco Friendly** – Exceptional low noise rating with low mechanical vibration.
- **Marine Compatible*** see warranty disclaimer – No exposed copper.
- **Tool-less Assembly** – For Easy maintenance. No special tools required.
- **Rotor Stop Protection** – Sensors automatically cut power in the event that the impellor stops rotating, reducing the chances of motor burnout.
- **Soft Start** – Rotor starts at low speed and increases over a short period of time. This reduces sudden recoil kick back on start up.

BENEFITS INCLUDE

- PondMAX Fountain & Pond pumps are suitable for use in many different applications including fountains, water features, aquatic systems, aquarium applications and hydroponics. The pumps can be used in submersible applications.
- Your pump has a single moving part (an impellor set) enabling easy cleaning and maintenance.
- The models EV1900 – EV13600 Pumps have intelligent circuitry that analyses the speed and torque of the motor. It will increase and decrease the energy usage to maximise efficiency.
- PondMAX Submersible Pumps are continuous rated therefore are designed to operate 24/7.
- An optional fountain kit can be purchased and fitted to the models EV650 – EV4900 pumps. Some of these models include a sponge pre-filter that assists in straining the partials in the water, to assist the fountain nozzles becoming blocked up with debris. See your retailer for options.

The soft start nature of the system helps to avoid sudden jolting at start up. The intelligent system will change the motor speed to maximise the flow of water in the given circumstances. If the impellor gets jammed or stops, the circuitry will sense the state and cut the power automatically for 3 seconds and then power up again.

This procedure will repeat 3 times. If the rotor is still jammed, it will activate a prolonged low state, till the pump is turned off, and adequate maintenance is carried out. Thus minimising motor burnout, due to electrical heat, through lack of water flow through the motor.

- The motor and electrical components are totally encapsulated in epoxy resin, ensuring safe operation under water.
- The pump has a robust bearing and shaft design so no Oil/grease lubrication is required.
- PondMAX pumps, that have plastic impeller parts and ceramic shafts, can be used in Marine applications as

there is no exposed copper. For Marine use, please see warranty disclaimer.



IMPORTANT SAFEGUARDS

Please read the operating instructions and familiarise yourself with the equipment before placing it in service. Correct and safe use of the system requires strict compliance with the safety instructions. For safety reasons, persons less than 16 years of age or infirm persons that are not familiar with these instructions should not use this equipment.

- Any damage to the equipment or unmerited operation will bring dangers to the surrounding precincts, so it must not be used. The equipment should be placed out of reach of children.
- For your own safety, disconnect from the power supply before any maintenance of any equipment is attempted on the tank or water body. Always unplug the pump from the power supply when not in use. Never pull the cable to disconnect the plug from the power supply - Grasp the plug and pull to disconnect. If required, have a qualified electrician install a weatherproof power supply point near to the pond or water-feature (within the cable length of the appliance).
- Be sure the equipment is submerged completely in the water. The depth should not be greater than 2m.
- Do not operate the pump if the appliance or any components of the system, such as the power cable, have been damaged. Check appliance for defects regularly.
- Always use a properly grounded power supply that is connected to an RCD with a rated residual operating current not exceeding 30mA. As per AS/NZS 3350.2.41:1997
- To avoid an electric shock, do not attach the plug to the power supply socket with wet hands. The drip loop method should be used to prevent water from traveling down the cable and onto the plug or power supply. If the plug does get wet, do not unplug the cable. Disconnect the circuit breaker that supplies power to the power supply point. Then unplug and examine the plug and power supply point for presence of water. If the power point has become wet, you should consult an electrician before using the power point again.
- Do not install or store the appliance where it will be exposed to extreme hot or cold temperatures. Do not use in water above 35°C.
- **Do not cut the cable as this will result in voiding your warranty.**
- Care should be taken to arrange the power cable so that it cannot be accidentally tripped over or pulled.
- Do not attempt to repair the electrical appliance yourself. Return to an authorized service centre or place of purchase if a fault occurs, (regular maintenance is not considered repair and is required by user).

PRODUCT SPECIFIC SAFEGUARDS

- Do not operate the pump without water at any time, permanent damage may occur.
- Be sure the equipment is submerged completely in the water. The depth should not be greater than 2m.
- The pump is designed to be used in a Garden pond/ waterfeature or Aquarium environment. It is not to be used in any other manner or purpose.
- The pump should only be used in clean water. Do not use the pump in, or with, any chemicals such as a solvent or gasoline.
- All PondMAX Submersible pumps are cooled by water flowing through the inside of the motor body. If the pump flow becomes restricted it will overheat and could cause permanent damage. Large tubing size is strongly recommended to deliver adequate water flow to cool the pump.
- The pump needs to be cleaned regularly to prevent the pump becoming blocked, thus causing the pump to

overheat and burn out. This is not a warrantable event. It is strongly recommended not to select a pump that is too small for the job required. The flow rate through the pump needs to be enough so that a half of the rated max flow is kept running at all times.



SUBMERSIBLE WATER PUMPS

INSTALLATION

For your convenience, a filter-less cage has been used on this model. It has a flat section on the front nose. This is to facilitate a vertical mount is necessary.

- A basic plastic fountain kit is not recommended for pumps that have flow over 6000L/hour. It's better to use commercial fountain nozzles for higher flow. If using fountain nozzles, it is recommended that a sponge pre-filter be used. See your local dealer for examples.
- If used to supply water to a waterfeature, cascade, waterfall, etc; where a pipe is needed to be used, use the hoses supplied in the package. For best results, use the bigger tubing size recommended in the table previously. Depending on the pump size, select the hose required for your tubing size and evaluate which step on the hose will be used. If you are using 50mm hose and you are connecting it to the 40mm/50mm hose supplied, remember to saw off the smaller size connection (I.E.: 40mm step). Otherwise it will create a unnecessary restriction in the system.
- Using a suitable thread seal tape (or other sealing compound) apply a liberal amount on the male thread of the hose.
- A omni-directional ball-joint is provided for your convenience when used under water. This is because the diagonal side sections of the ball-joint may seep water when in use. The fittings pack include the necessary O'Ring washers. Select the one that will fit the female connection of the ball-joint. Place it firmly in the locking nut. Now screw the locking nut of the ball-joint onto the outlet of the pump. Fasten firmly but do not over tighten.
- Then connect the 1 1/2" threaded bush to the outlet of the ball-joint. Then connect the hose to the bush and screw in firmly. To seal adequately, use thread seal tape on this male thread.
- Now connect the tubing to the hose. Remember to use Stainless Steel hose clamps to fasten the hose on to the hose. This is to ensure that the hose does not blow off at a later time or there become a leak at this point in the plumbing system.
- When used in a pond environment place the pump in desired location; ensure the pump is on a stable surface that is free of sludge, sand and other debris. Position the device in the pond horizontally, on a solid base, in such a way that it is fully covered with water and ensure that the pump is located, at a depth, in the water, which will not allow it to suck air from the surface. This is known as cavitation. Cavitation is a cause of premature impeller wear.
- Direct the hose to your desired location.
- To power up, push the plug into the power supply outlet and switch on. Use the power supply switch for turning the unit on and off.

CLEANING INSTRUCTIONS

Begin by ensuring that the mains power supply is disconnected before attempting any maintenance or adjustment of the unit or the water body. Remove the unit from the water. If your unit is connected to a sponge filter, the filters and sponges will clog up over time. Please clean regularly (at least once a month) to ensure strong water flow. Failure to maintain the unit will result in a burnt out motor and other damage.

- All Evoll Submersible pumps are water cooled, if pump becomes restricted, or blocked, it will overheat and could cause permanent damage.
- The motor unit of the pump is encapsulated with epoxy resin and does not need lubrication. Regular inspections, cleaning and maintenance of impellor is necessary to ensure longer life. In the centre of the impellor you may notice a small hole opening that protrudes through the ceramic shaft from front to back. It is paramount that this portal is kept unblocked at all times. This is a cooling channel for the motor.
- If using a fountain kit, take off the fountain set first by unscrewing it from the top of the pump. Examine the nozzles to ensure all ports are unblocked. Clean with a suitable brush if necessary.
- Maintain the filter sponge regularly according to how long it takes for the sponge to get clogged up. When the flow starts to be reduced, check and clean if necessary.
- To unclip the front filter cage from the front of the pump, twist the cage in an anti-clockwise direction and pull forward. If available, take out the optional Internal Bio sponge and clean. If using an optional pre-filter block sponge, slide the sponge off the threaded core and wash out. It is recommended that this is done in a bucket of pond water to ensure the good bacteria that are present in the sponge are not killed by the Chlorine in tap water. Check for wear and tear of the sponges. Replace if necessary.
- You can help boost the biological function of your filter sponge with a bacterial additive, available from your local stockist.

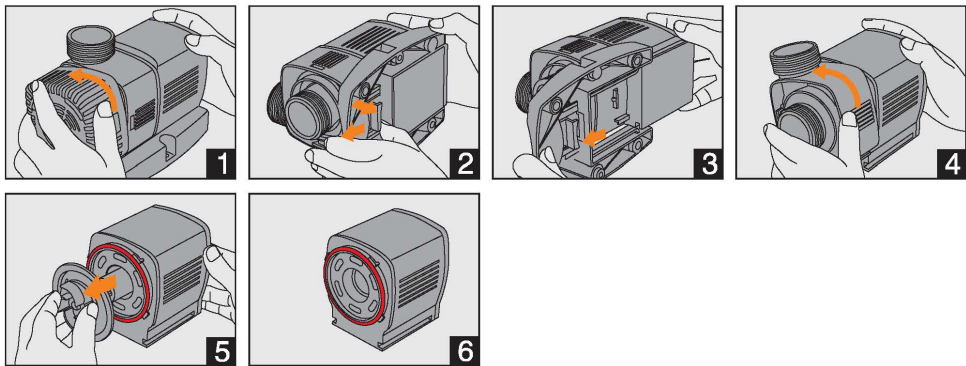

1. Turn the filter case in the direction as indicated by the arrow, then lift it off.
2. Unclip the snap-fit catch under the base plate, and drawn out in the direction of the arrow.
3. Take off the base plate.
4. To maintain the impellor of the pump, turn the Impellor Cover in an anti-clockwise direction as indicated by the arrow, to the stop position. Then separate the impellor cover from the pump motor body.
5. Lift out the impellor assembly. (Take care not to break ceramic shaft.) The black disc behind the blades is part of the entire impellor assembly. Clean the impellor with clean water and a suitable brush taking note to remove fine sediment on and around the back end of the impellor including the small hole through the ceramic shaft if it has one. Replace the impellor if necessary.
6. Ensure to replace the O'ring in the correct place shown in the picture when reassembling the unit.

SUBMERSIBLE WATER PUMPS

IMPORTANT NOTES

- It is important to ensure that this is carried out regularly as the cooling path inside the motor will become clogged. If the impellor assembly becomes worn or damaged it should be replaced (available from your dealer or special orders). Failure to do so may cause serious damage to pump. Inspect for signs for wear and tear. The impellor set is a wearing consumable part.
- Once the cleaning and inspection process is completed, reassemble in the reverse manner. Reinstall the impellor into the motor body.

To place the Impellor O'Ring around the black disc successfully, firmly hold the disc with one hand, and using the other hand stretch the O'Ring over the disc, positioning it carefully into the groove. Pay attention not to allow the O'Ring to roll forward, in-between the black disc and the motor body.

With the impellor in the correct position, carefully place the impellor cover back on, and then rotate clockwise back into position.

- On some models re-insert the internal sponge back into the filter cage and reattach to the pump. On other models re-attach the front filter screen.
- Now re-attach the sliding base back into position to lock the impellor cover from turning.



EXPLODED VIEW

- 1 Sponge Filter cage.
- 2 Internal Sponge Pre-filter Insert
- 3 Flow Adjuster Knob - [EV1900 - EV4900]
- 4 Front filter Screen - With hole for flow adjuster - [EV1900 - EV4900]
- not shown Blanking Cap for Hole in Front Filter Screen (optional)
- 5 1" Threaded Bush - for optional Pre-filter Bio-sponge.
- 6 Threaded Hosetail for Inlet - 1" BSP to 25mm Tube
- 7 Impellor Cover Housing
- 8 Impellor Assembly
- 9 Impellor cover O'ring
- 10 Sliding Base with Rubber Feet
- 11 Pump Motor Body
- 12 Reducing Bush - 1" to 1 1/2" BSP Threaded.
- 13 O'ring for Ball Joint and Hosetails, Red
- 14 Uni-directional Ball Joint for Submerged Use.
- 15 Threaded Bush - 1 1/2" BSP
- 16 Hosetail with - 1 1/2" BSP Thread to 50/40mm Tubing
- 17 Hosetail with Locking Collar - 1 1/2" BSP Thread to 40/32/25mm Tubing
- 18 Front filter screen - (no flow adjuster) *EV7200 & EV9200 only*
- 19 Front filter screen - (no flow adjuster) *EV11200 & EV13600 only*

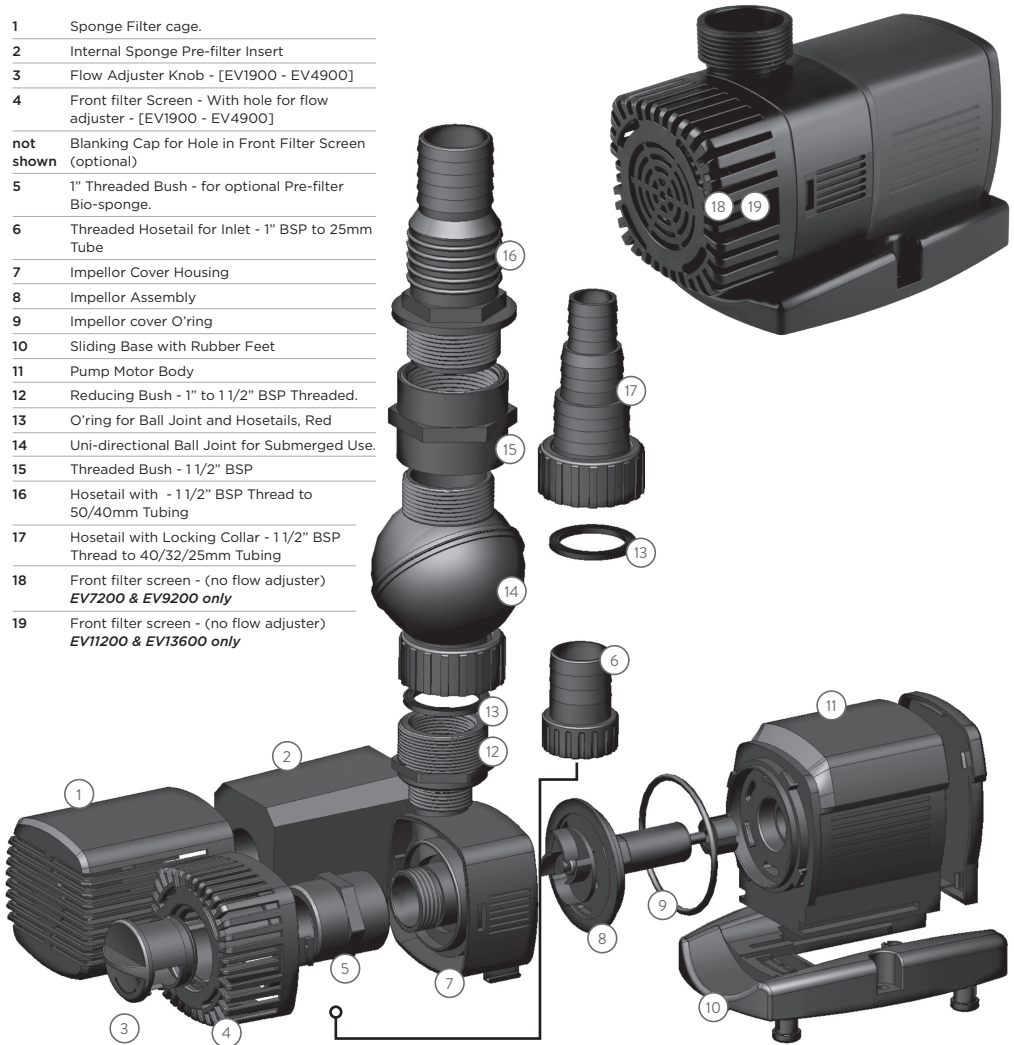

NOTE: Parts and features differ from model to model. All images used are for illustrative purposes only. Not all features depicted apply to all models in the range and these are subject to change.



IMPORTANT

These accessories and attachments are recommended for use with your PondMAX product specified in this manual. The use of any other accessories or attachments might present a risk of injury to persons. Only use the accessory or attachment for its stated purpose.

SUBMERSIBLE WATER PUMPS

PART NO.	DESCRIPTION	EV-7200	EV-9200	EV-11200	EV-13600
1	Sponge Filter cage.				
2	Internal Sponge Pre-filter Insert				
3	Flow Adjuster Knob - [EV1900 - EV4900]				
4	Front filter Screen - With hole for flow adjuster - [EV1900 - EV4900]				
Not Shown	Blanking Cap for Hole in Front Filter Screen (optional)				
5	1" Threaded Bush - for optional Pre-filter Bio-sponge.				
6	Threaded Hosetail for Inlet - 1" BSP to 25mm Tube				
7	Impellor Cover Housing	-	-	-	-
8	Impellor Assembly	12EV029	12EV030	12EV031	12EV032
9	Impellor cover O'ring	-		-	
10	Sliding Base with Rubber Feet				
11	Pump Motor Body				
12	Reducing Bush - 1" to 1 1/2" BSP Threaded.				
13	O'ring for Ball Joint and Hosetails, Red				
14	Uni-directional Ball Joint for Submerged Use.				
15	Threaded Bush - 1 1/2" BSP	-			
16	Hosetail with - 1 1/2" BSP Thread to 50/40mm Tubing	-			
17	Hosetail with Locking Collar - 1 1/2" BSP Thread to 40/32/25mm Tubing				
18	Front filter screen - (no flow adjuster) EV7200 & EV9200	-			
19	Front filter screen - (no flow adjuster) EV11200 & EV13600			-	

2, 9, 12, 13, 14, 17	Complete Kit EV1900-EV4910-DC - O'rings, Inlet & Outlet, Threaded Bushes and Uni-directional Balljoint.				
9, 13, 14, 15, 16, 18	Complete Kit For EV7200-EV9200 - O'rings, Inlet & Outlet, Threaded Bushes and Uni-directional Balljoint.	-			
9, 13, 14, 15, 16, 18	Complete Kit For EV11200-EV13600 - O'rings, Inlet & Outlet, Threaded Bushes and Uni-directional Balljoint.			-	

TROUBLESHOOTING

Problem	Reason	Solution
WATER PUMP NOT WORKING	No Power	Check that the plug is connected and power point turned on.
	Sponges and filter media blocked with sludge.	Clean the sponges and filters.
	Impellor is blocked with sludge or lime scale build up.	Clean the Impellor as per the instructions.
	Running without sufficient water.	Submerge the equipment underwater then plug in. Refill if necessary.
	Blocked Impellor chamber or ceramic shaft is broken.	Clean the Impellor. Check for wear. Replace if necessary.
WATER PUMP IS NOISY	Blockage in pump.	Clear the blockage.
	Impellor & Shaft worn out.	Replace Impellor & Shaft.
	Impellor broken.	Replace Impellor.
	Water valve closed on the inlet or outlet.	Open the valve.
	Unit inlet is blocked or the water pump outlet is blocked.	Clear all blockages.
	The height to which you are pumping is too high for the given model of pump.	Select a bigger model.

SUBMERSIBLE WATER PUMPS

LIMITED WARRANTY 2+1 YEAR

- The additional 1 Year Extended Warranty applies when you REGISTER with Aquatec Equipment. See enclosed for details and please retain your proof of purchase and Warranty form.
- Warranty covers only appliance defects and faulty material and workmanship within a 2 year period.
- Faults arising due to accidents, misuse, not following manufacturer's guidelines/ instructions or power surges/spikes/brownouts will not be covered.
- The impellor set is a consumable item and is therefore not covered under warranty.
- Warranty will be void if any tampering removal of warranty labels or electrical circuitry is evident.
- Warranty will be void if the power cord is cut or damaged in any way.
- Warranty will be void if any visible signs of overheating are present.
- Loss of livestock, damage to property or personal injury caused by this product will not be covered.
- Warranty claims caused by installation faults will not be covered.
- It is the customer's responsibility to return the faulty appliance for any warranty claim, to Aquatec.
- For any warranty to be valid, an original proof of purchase must be provided.
- Our goods come with guarantees that cannot be excluded under the Australian Consumer Law. You are entitled to a replacement or refund for a major failure and for compensation for any other reasonably foreseeable loss or damage.

You are also entitled to have the goods repaired or replaced if the goods fail to be of acceptable quality and the failure does not amount to a major failure.

- **A Warranty claim must be made within 2 years of the date of purchase.**
- **If used in Marine or Salt water, due to the harsh conditions, there is only 1 year warranty.**

EXTENDED WARRANTY

- The Extended Warranty period is for an additional 1 Year and commences on expiration of the standard Warranty period.
- Application for Extended Warranty is FREE of any registration cost to the purchaser on completion of the Extended Warranty questionnaire can be found in the box with the item purchased or online at www.aquatecequipment.com.
- Please keep a copy of the registration form in a safe place together with your proof of purchase (sales receipt). Both documents will be required for any claim under this extended warranty.
- Where Aquatec determines goods are being used in a manner contrary to the instructions, specifications or this Warranty, Aquatec reserves the right to terminate Extended Warranty for such goods and will provide written notice to the purchaser.

Please consult your retailer for quality original PondMAX replacement parts.

Visit www.aquatecequipment.com for your nearest stockists.

E.&O.E.



FOR GARDENS THAT GO THE EXTRA YARD



AQUATEC
EQUIPMENT

HOTLINE 1300 AQUATEC

www.pondmax.com.au