



CENTURIONPRO

ELITE TRIMMING TECHNOLOGIES



SEW
EURODRIVE



OWNERS MANUAL

BUCKERS: HP1, HP3



IMPORTANT SAFETY INFORMATION

CENTURION PRO SOLUTIONS: HP BUCKERS

The HP Buckers are high-powered machines that require special safety precautions to be practiced while in operation to reduce the risk of personal injury. Improper use of the HP Bucker may cause serious or fatal injury. Please read the precautions and warning labels before using the HP Bucker.

**DO NOT LEND OUT OR RENT YOUR HP BUCKER WITHOUT THIS OPERATING MANUAL.
A FIRST TIME USER SHOULD OBTAIN PROPER INSTRUCTION PRIOR TO USE.**

OPERATING THE HP BUCKER WITHOUT READING THE INSTRUCTIONS THAT ACCOMPANY A CAUTIONARY LABEL (IE. "DANGER", "CAUTION", "WARNING", OR "NOTICE" SYMBOL), MAY RESULT IN SERIOUS OR FATAL INJURY.

GENERAL

- Do not move, disassemble, clean or inspect the Bucker while the power is still connected to the machine.
- The Buckers are very heavy - Never lift alone and always use proper lifting techniques.
- Ensure unit is secured to the stand, or is on a hard and leveled surface.
- Replacement parts are specific to The Buckers and must be purchased from an authorized dealer only.
- Substituting factory parts with non-approved third-party replacements may result in damage to the machine or bodily harm.
- Keep all individuals a safe distance from the work area. Do not operate the machine around children.
- Do not remove safety labels. Replace any and all labels if they become damaged or obscured

CONNECTION

- As with home appliances, HP Buckers must be used in connection with a properly grounded receptacle.
- Never plug in or power up your Bucker machine if the protective shrouds are removed.
- Do not use extension cords smaller than 12 gauge or longer than 7.6m (25ft) in length to power the Bucker.
- Using unrated extension cords can cause motor overheating and premature failure.

OPERATION

- HP Buckers comes from the manufacturer set with the optimal roller settings. The initial set up will show assembly instructions.
- Safety glasses and dust masks must be worn at all times when operating Buckers.
- Do not operate any Bucker machine while tired or under the influence of medication, drugs or alcohol.
- Do not put anything other than plant material into the Bucker. Doing so may cause damage to the machine or result in bodily harm.
- Operate the Bucker in a well ventilated area in order to prevent overheating.

MAINTENANCE

- Never leave the HP Bucking system running unattended.
- Never conduct maintenance or cleaning while the machine is plugged in.
- Do not modify or adapt any part of the Bucker or its accessories. Doing so may cause irreversible damage to the machine or result in bodily harm.

FOR OPTIMAL PERFORMANCE AND LIFE, THE BUCKER MUST BE CLEANED AFTER DAILY USE.

SEW
EURODRIVE



TABLE OF CONTENTS

IMPORTANT SAFETY INFORMATION	2
TABLE OF CONTENTS	3
COMPONENT OVERVIEW	4
CONTROL PANEL / EMERGENCY STOP OVERVIEW	5
CLEANING MAINTENANCE	6
ASSEMBLY TO STAND - HP1 & HP3	7
GENERAL OPERATIONS	8
PLANT PREP 101	9
GENERAL PERFORMANCE SPECIFICATIONS HP1	10
GENERAL PERFORMANCE SPECIFICATIONS HP3	11
TROUBLE SHOOTING	12
FREQUENTLY ASKED QUESTIONS	12
ADDITIONAL ASSISTANCE	13
WARRANTY	13

HP1 - ADDITIONAL REQUIREMENTS	
EXTENSION CORD	14 AWG (min AWG SIZE)
	7.6m/25ft MAX LENGTH

HP BUCKER CONNECTIONS	
CANADA, USA, MEXICO & JAPAN CONNECTOR PLUG REGULAR WALL OUTLET	

HP3 - ADDITIONAL REQUIREMENTS	
EXTENSION CORD	12 AWG (min AWG SIZE)
	7.6m/25ft MAX LENGTH

HP BUCKER CONNECTIONS	
EUROPE, SOUTH AMERICA & ASIA CONNECTOR PLUG REGULAR WALL OUTLET	

COMPONENT OVERVIEW

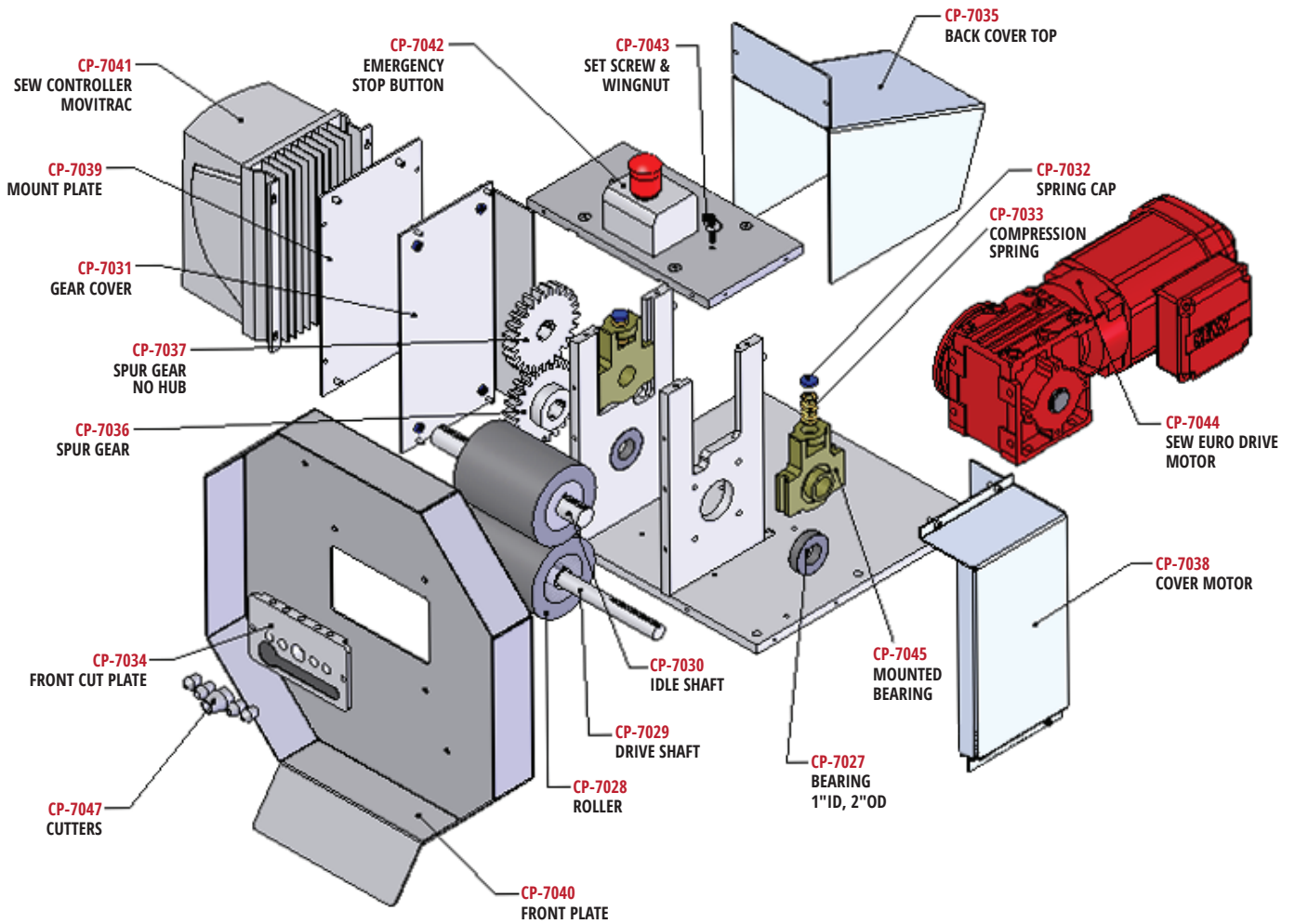
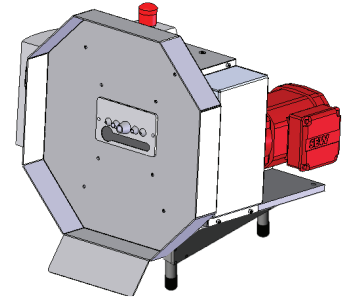

CONTROL PANEL OVERVIEW

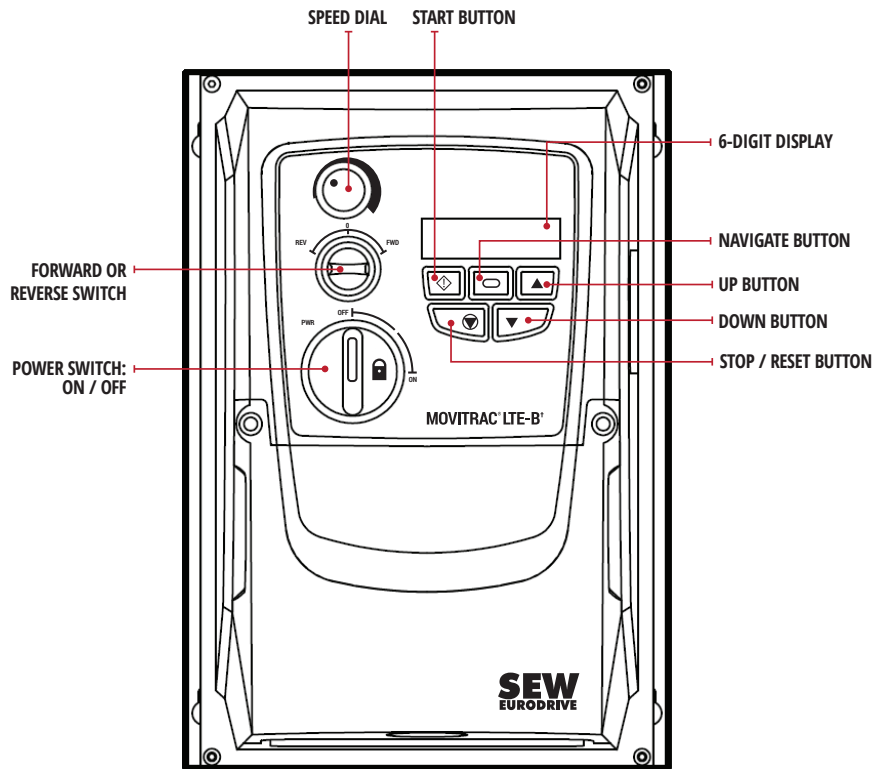

EMERGENCY STOP BUTTON OVERVIEW

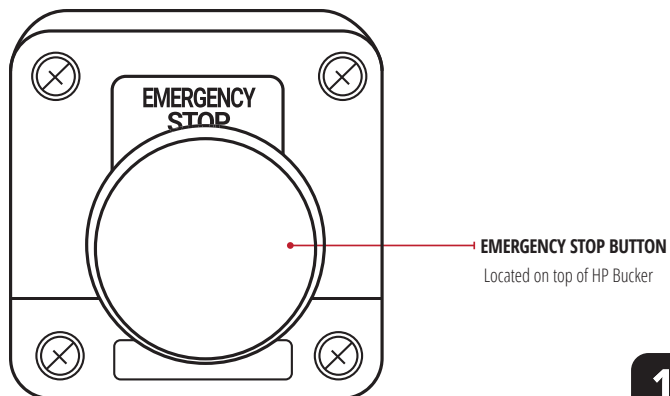

CLEANING & MAINTENANCE *Ensure machine is unplugged before cleaning.

STEP 1: REMOVE FRONT PLATE

A) Remove using:
8 - 3/16" x 1" bolts

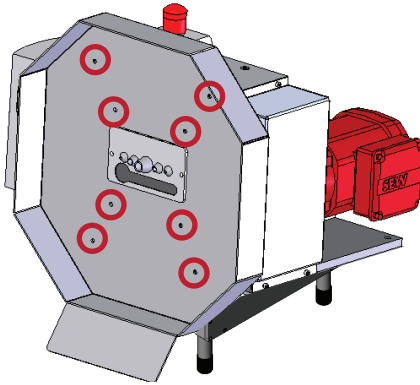

STEP 2: REMOVE FRONT CUT PLATE

A) Remove using:
2 - 3/16" x 1" bolts

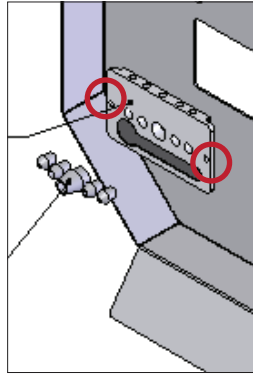

STEP 3: CLEAN BOTH ROLLERS WITH CLOTH

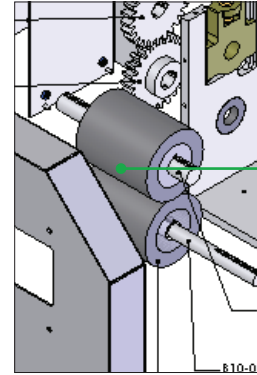

STEP 4: CLEANING

Thoroughly clean
inside bucker by
removing all loose
debris & blockage.

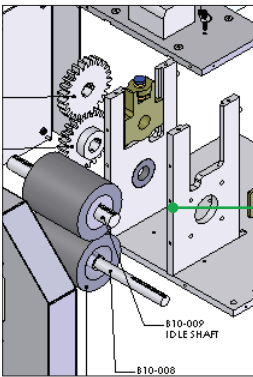

STEP 5: REASSEMBLE BUCKER

Re-assemble bucker
in reverse order.

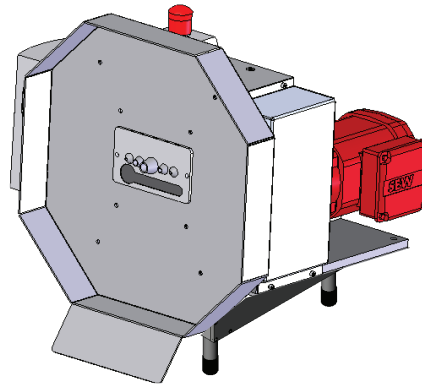

**FOR OPTIMAL PERFORMANCE AND LIFE, THE BUCKER
MUST BE CLEANED AFTER DAILY USE.**

ASSEMBLY TO STAND

STEP 1: REMOVE LEGS

Unscrew legs from
Bucker (HP1 only).

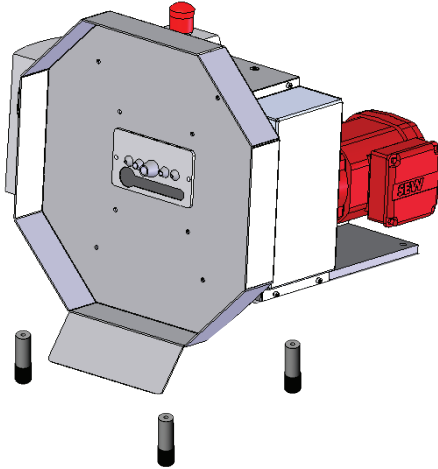

STEP 2: MOUNT BUCKER ONTO STAND

A) Line up existing holes of the
bucker to the holes on the
stand plate. Attach using:
6 - 3/16" hex top
1/4"-20 x 1.25" bolts
Repeat 3x for the Triple Stand

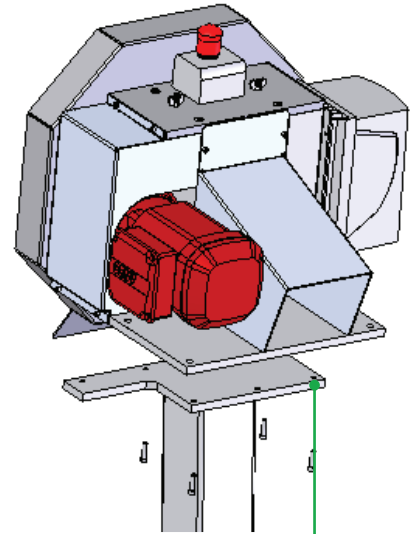

STEP 3: PLUG IN AND START BUCKING

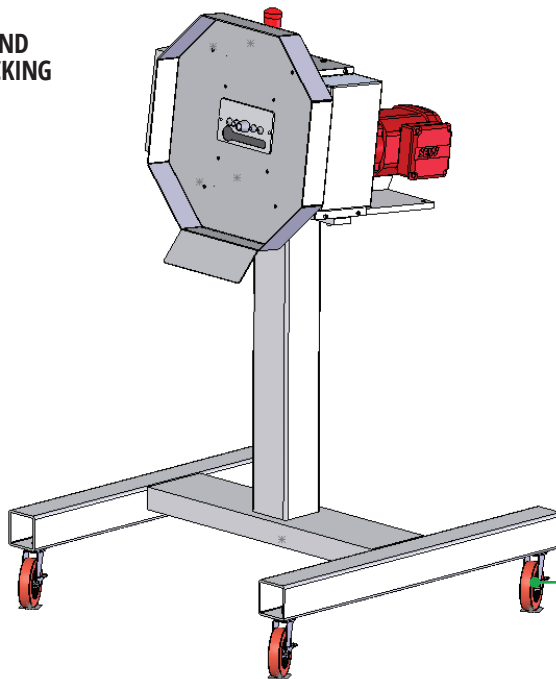

**Optional Off-road tire can
be bolted onto stand



GENERAL OPERATIONS

PREPPING YOUR PLANT: 2 STEPS FOR OPTIMAL PROCESSING

1) ENVIRONMENT PREPARATION

- Ensure adequate space
- Review electrical requirements
- Have adequate bins for product transport
- Cooler temperatures in processing room is beneficial

2) PLANT PREPARATION

- Cut main stalk
- Separate each individual stem (no 'Y' junctions)
- Leave 3" of stem for clearance into machine
- Ensure clean angled cuts for precise feeding
- Keep prepped product stem side up for efficiency
- Size the stem to fit the ideal hole
- Feed end first into machine
- Use variable speed control to adjust flow

CLEANING

A thorough cleaning of the HP Bucker should be performed after each use. Any resin build-up on the machine attracts more resin, compounding the problem. Build-up can cause decreased performance, overheating and could trip your circuit breaker. Future cleaning also becomes more difficult if build-up is given a chance to dry out and harden. Operating the HP Bucker in a cold environment will also reduce resin build-up.

After removing front and back plates, rollers can be cleared using hot water, or wiped with isopropyl alcohol. Repeat 2-3 times to soften the resin, then powerwash to remove debris. Any stubborn areas, may require scrubbing with a plastic scraper (do not use a metal scraper). Plant matter build-up is the most obvious sign that more attention is needed in a particular area. Dry the machine with compressed air or a soft cloth.

Directions for cleaning:

1. Make sure Bucker is turned off
2. Using provided tools, remove Front Plate and Back top plate
3. Wipe down front plate liberally with isopropyl alcohol
4. Wipe down using a soft cloth, making sure the machine is dry completely
5. Clear out any debris from within the Bucker
6. Spray rollers liberally with isopropyl alcohol
7. Wipe down using a soft cloth, making sure the machine is dry completely
8. Reassemble according to "Cleaning and Maintenance" section

MATERIALS NEEDED

- Tool kit provided with Bucker
- Brush / Plastic scraper
- Spray bottle filled with isopropyl alcohol
- Soft cloths

INSPECTION

Inspection of the either HP Bucker should be conducted prior to each use following the disassembly section on page 6 and these steps:

1. Unplug the Bucker and visually inspect all of the components for wear, damage and plant matter build-up.
2. Remove the front plate and back top plate. See "Cleaning and Maintenance" section for instructions.
3. Inspect the rollers for damage or cracking.
4. Ensure the rollers spins freely
5. Visually inspect the blower and ensure the Bucker is free of loose debris.

MACHINE MAINTENANCE

The HP Bucker is a precision machine. It is essential that it is operated and maintained with this in mind. The machine has been adjusted and tested by the manufacturer prior to shipping to ensure optimal performance. However, it is important to inspect the machine at initial start-up and after each use to ensure that no damage or plant material build-up has occurred and that the rollers spin freely.

In addition, it is highly recommended to clean the machine at the end of every use. This ensures that resin does not build-up and affect performance. This is especially important if the machine has been stored for an extended period of time.

Resins and other plant by-products will build up and harden, becoming difficult to remove. Cold water is recommended to spray on rollers during harvest to reduce build-up.

NOTE

- There are a series of holes located on the front of the top plate for bucking
- Stems are fed through the holes of the machine by hand
- Each plant must have 3 inches of base stem to clear the buckers
- Please note all strains run differently and denser strains may need the top colas taken off before being run through the machine.

PLANT PREPPING 101



3 STEPS FOR OPTIMAL PROCESSING



ENVIRONMENT PREPARATION

- Ensure adequate space
- Review electrical requirements
- Have adequate bins for product transport
- Cooler temperatures in processing room is beneficial



PLANT PREPARATION

- Cut main stalk
- Separate each individual stem (no 'y' junctions)
- Leave 3" of stem for clearance into machine
- Ensure clean angled cuts for precise feeding



FEEDING

- Keep prepped product stem side up for efficiency
- Size the stem to fit the ideal hole
- Feed end first into machine
- Use variable speed control to adjust flow

DRY BUCKING TIPS

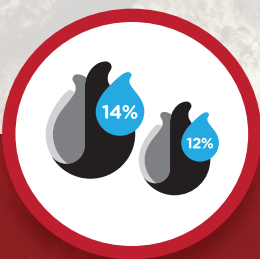

MOISTURE CONTENT

- Moisture content is critical for ensuring minimal damage to the flower
- Flower that is too dry will fall apart
- Flower that has too much moisture will compact and dent
- For best results with dry bucking, moisture content should be between 12% and 14% when using a machine



BUD CONSISTENCY

- Buds should be "springy" - when the flower is squeezed between two fingers it will rebound and return to its original shape
- Both big and smaller stems must be pliable when bucking with a machine such as a GC or HP System
- Pliable stems ensures that they fold and are stripped upon entering the bucking machine. If too brittle, they will simply break off and will not be properly stripped



MACHINE SPEED

- Slowing the machine speed for dry bucking will lead to a better result
- Dry bucking at 1/2 or 1/3 of the regular speed will ensure better results
- The variable speed control offered by our HP Bucker is a great feature when bucking dry material

HP1 BUCKER SPECIFICATIONS

HP1 BUCKER	
Input Voltage	NA: 5 Amp - 120V, 60Hz Single Phase EU, AUS: 2.5 Amp - 240V, 50Hz Single Phase
Current Draw	< 2.5A Operating
Drive Motor	0.75HP, IP54
Motor RPM	1690 RPM
Variable Speed	Yes
Weight (w/ stand)	200lbs / 90kg
Length	24in / 61cm
Width	18in / 46cm
Height	22in / 56cm
Circuit Breaker Required	NA: 15A/120V EU, AUS: 15A/220V

HP1 BUCKER FEATURES	
Feed Throughput	+175 lbs/hr (Hydrated)
Feed Entry Sizes	5-hole (3/16", 1/4", 3/8", 1/2", 3/4")
Feed Types	Wet/Dry
Roller Sets	Neoprene Rubber
Motor Pulse	Yes
Reverse Operation	Yes
Duty Cycle	Continuous
Pull Speed	10-30 in/s
Pull Strength	> 400 lbs
GMP Compliant*	Yes
UL Compliant*	Yes
CE Compliant*	Yes
RoHS Compliant*	Yes
Primary Material	304 Stainless Steel / Aluminum

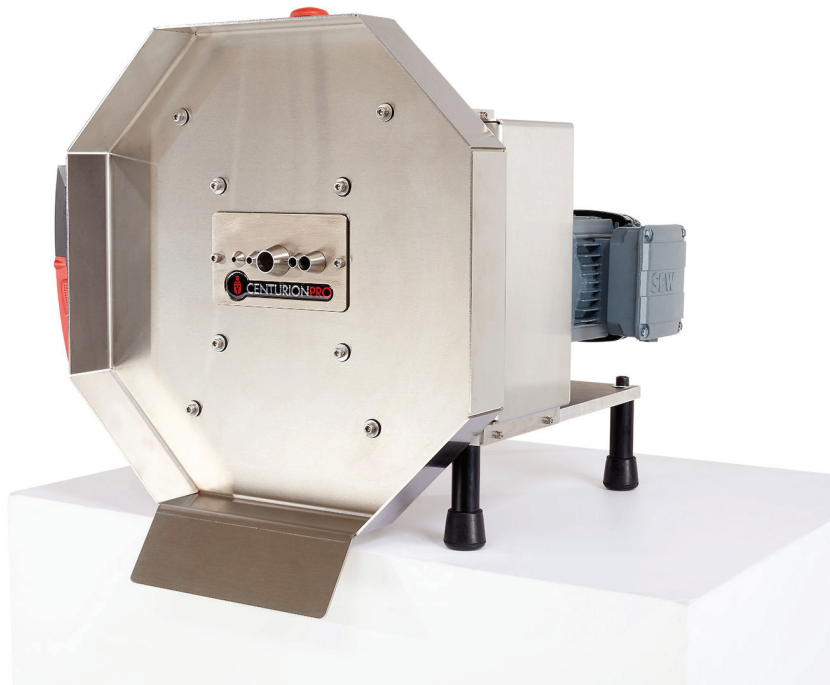

HP3 BUCKER SPECIFICATIONS

HP3 BUCKER	
Input Voltage	NA: 15 Amp - 120V, 60Hz, Single Phase EU, AUS: 7.5 Amp - 240V, 50Hz Single Phase
Current Draw	7.5A Operating
Drive Motor	0.75HP, IP54 (x3)
Motor RPM	1690 RPM (x3)
Variable Speed	Yes
Weight (w/ stand)	500lbs / 227kg
Length	85in / 216cm
Width	32in / 82cm
Height	51in / 130cm
Circuit Breaker Required	NA: 20A/120V EU, AUS: 20A/220V

HP3 BUCKER FEATURES	
Feed Throughput	+500 lbs/hr (Hydrated)
Feed Entry Sizes	5-hole (3/16", 1/4", 3/8", 1/2", 3/4")
Feed Types	Wet/Dry
Roller Sets	Neoprene Rubber
Motor Pulse	Yes
Reverse Operation	Yes
Duty Cycle	Continuous
Pull Speed	10-30 in/s (x3)
Pull Strength	> 400 lbs (x3)
GMP Compliant*	Yes
UL Compliant*	Yes
CE Compliant*	Yes
RoHS Compliant*	Yes
Primary Material	304 Stainless Steel / Aluminum



TROUBLE SHOOTING

1) MOTOR IS VERY HOT

The motor is designed to operate at higher temperatures, avoid contact with the motor during regular operation. The motor is thermally fused and will shut down automatically if overheating occurs

2) MACHINE IS JAMMED, OR MISFED WITH PLANT MATTER

This can happen when too large of a branch is put through the machine. Press and hold the reverse pulse button to rotate the rollers backwards while pulling on the branch.

3) THERE IS A GRINDING SOUND COMING FROM THE MACHINE

This can be caused by worn out bearings, misaligned gears or improperly installed components. If the pull-wheels were recently replaced / cleaned; then it is likely an alignment issue, otherwise the bearings are damaged and need replacement.

4) THE PULL FORCE SEEMS WEAK

This could be caused by excessive debris build-up in the rollers. Disassemble, clean and inspect machine to determine the issue.

5) ROLLERS ARE SLIPPING

Slipping occurs if the motor reaches it's torque limit, or the roller friction has been reduced. Roller friction can be reduced by feeding excessively wet material or if any lubricants accidentally get on the roller. Check to see if the rollers are dry and clean.

6) WHAT SPEED SHOULD I USE FOR WET MATERIAL?

We recommend a faster speed for wet product and a slower speed for dry.

7) DOES THE STEM HAVE TO BE A CERTAIN LENGTH TO FEED TO THE BUCKER?

Yes, there must be 3 inches of base stem to clear the cutters.

8) DO I NEED A SPECIAL OUTLET FOR THE BUCKER?

CenturionPro Buckers can be plugged into any standard 110V wall outlet (220V AUS/EU).

9) DO THE HP or HP3 BUCKERS WORK BEST WITH A PARTICULAR STRAIN?

HP Buckers can handle any strain but please note that all strains run differently and denser strains may need the top colas taken off before being run.

FOR ALL OTHER ISSUES, PLEASE EMAIL techsupport@cprosolutions.com, WE WOULD BE HAPPY TO HELP YOU.

FREQUENTLY ASKED QUESTIONS

HOW EASY IS IT TO CLEAN?

Our machines can be taken apart and cleaned within 10-15 minutes. The Bucker must be cleaned after daily use. Just spray the rollers liberally with isopropyl alcohol, then wipe with a soft cloth. We recommend to clean every 4-6 hours of use, but it depends on your strain. We know the importance of down time during a harvest so we wanted to make this process extremely quick and easy

DO YOUR MACHINES TRIM WET OR DRY?

All CenturionPro Buckers trims both wet and dry to fit your processing needs.

ARE YOUR MACHINES BUILT TO AN INDUSTRIAL STANDARD?

We do not compromise quality for cost savings. All CenturionPro Solutions machines are composed of the highest quality materials available in North America and each machine is put through a comprehensive quality control inspection. We only use brand name components in the build out of our Bucker machines which enables us to have the comfort in giving you a 5 year warranty. With proper maintenance these machines will last you well over a decade.

WHAT IS THE OPTIMAL ROOM TEMPERATURE TO TRIM?

Use your CenturionPro Bucker in 50-60 °F (10- 15 °C) room to get the best performance. Cooler temperatures prevent excessive sticking to machine components.

MY MACHINE IS NOT WORKING LIKE IT DID WHEN IT WAS NEW, WHY?

Make sure to fully clean the machine and rollers. If the machine is clean and the rollers are free of debris, then your machine should trim exactly like it was new.

**WE ARE OPEN MONDAY THROUGH FRIDAY FROM 9AM TO 5PM PST - PH: 1-855-535-0558
FILLING OUT THE "CONTACT US" FORM ON THE WEBSITE, IS ANOTHER SURE WAY TO GET IN TOUCH.**

!! IMPORTANT !!

WARRANTY

YOU MUST REGISTER YOUR BUCKER WITHIN 30 DAYS OF YOUR PURCHASE

YOU HAVE JUST MADE A SMART DECISION BY PURCHASING THE BEST BUCKER IN THE WORLD. FAILURE TO REGISTER YOUR BUCKER WITHIN 30 DAYS OF PURCHASE WILL VOID YOUR 2 YEAR WARRANTY. PROTECT YOUR INVESTMENT. THIS PROCESS WILL ONLY TAKE 3 MINUTES TO COMPLETE.

TO REGISTER GO TO:

cprosolutions.com/warranty

WARRANTY TERMS AND CONDITIONS

CenturionPro Solutions (the manufacturer) will repair or replace, without charge, any parts proven defective in material or workmanship for a period of 5 years on the Bucker Machine.

The warranty period will begin on the date the machine(s) is purchased by the initial purchaser. Product or component warranty defects can be remedied at any authorized service dealer, or directly at the manufacturer. Any service work performed, and deemed valid due to a defective part, will be free of charge. CenturionPro Solutions reserves the right to use any manufacturer-approved replacement part for the warranty repair

The machine or defective part then must be returned to the manufacturer for analysis or replacement at the cost of the owner. Parts deemed to be covered under the warranty will be provided for free excluding shipping costs.

Do not return the machine to the place of purchase for repair or warranty claims, unless you have been authorized by CenturionPro Solutions to do so. The place of purchase can only sell replacement parts and will not repair any warranty issues, unless it is noted as an authorized repair dealer and has been authorized to work on your machine.

IF WARRANTY REPAIR IS REQUIRED, PLEASE CONTACT THE MANUFACTURER AT 1-855-535-0558 OR techsupport@cprosolutions.com AND PROVIDE THE FOLLOWING INFORMATION:

- | |
|--|
| 1. Model and serial number |
| 2. Proof of purchase date |
| 3. A copy of the original Warranty Registration Card or Online Submission |
| 4. Details of the defect or problem (include photos and videos) |

YOU MAY BE DENIED WARRANTY COVERAGE IF YOUR MACHINE HAS FAILED DUE TO ANY OF THE FOLLOWING:

Product abuse	Normal wear
Product neglect	Accidental damage
Improper maintenance	Unapproved modifications
Improper electrical connection	

LIABILITIES

The manufacturer assumes no risk and shall be subject to no liability for damages or loss resulting from the specific use or application made of the product. In no event will the manufacturer be liable for any special, incidental or consequential damages (including loss of use, loss of profit and claims of third parties) however caused - whether by negligence of the manufacturer or otherwise. If you have any questions regarding your warranty rights and responsibilities, please contact the manufacturer.

LEGALITIES

CenturionPro Bucker machines are intended for use on legal aromatic herbs and hops. Please check all municipal, provincial/state and federal laws and regulations before using these machines. CenturionPro Solutions does not promote or condone the use of these products in any way that may be deemed illegal. Allow only persons who understand this disclaimer to operate the machines.



CENTURIONPRO

ELITE TRIMMING TECHNOLOGIES



cprosolutions.com



1 855 535 0558



info@cprosolutions.com

FOLLOW US ON:

