

UNDER CURRENT®

THE PROVEN PRODUCTION SYSTEM

2019 ASSEMBLY INSTRUCTIONS

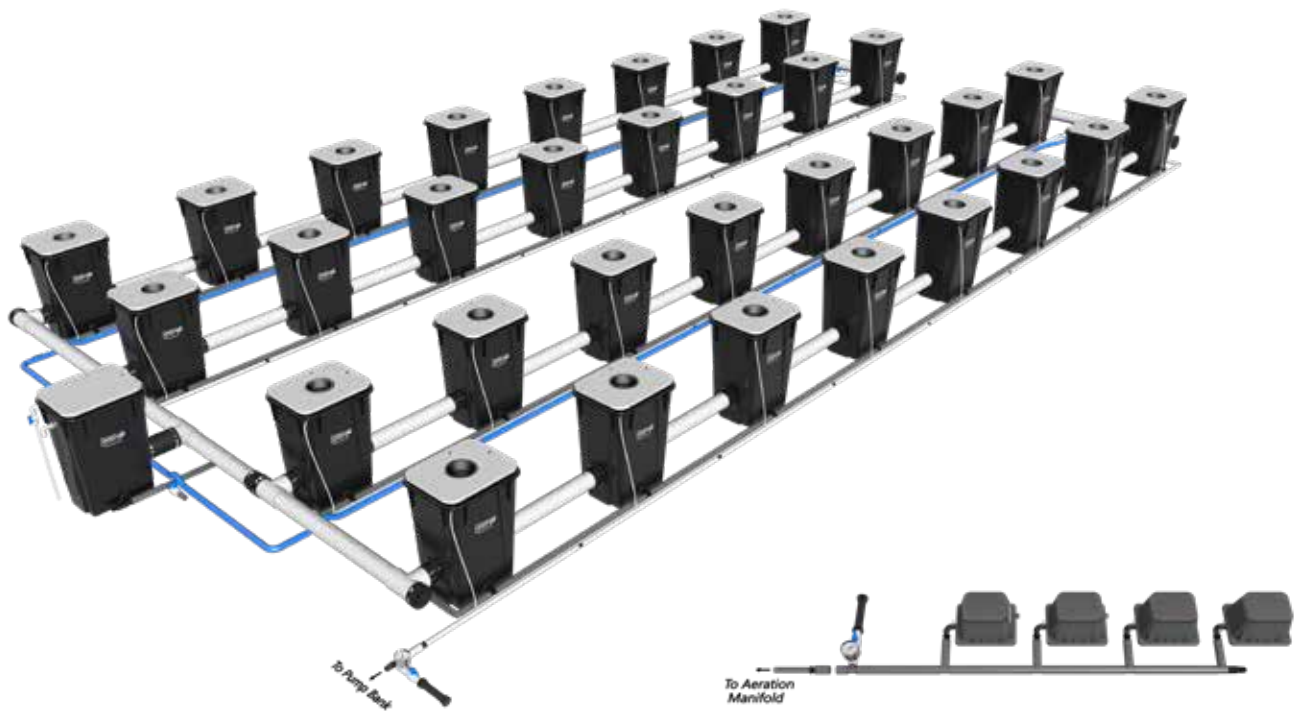

CULTIVATING HYDROPONIC EVOLUTION

THANK YOU!

Thank you for purchasing your Under Current® system. Your system was manufactured and packed with pride at our facility in Fresno, California.

Since 2006, the team at Current Culture H2O® has been dedicated to Cultivating Hydroponic Evolution. We uphold this mission by developing innovative and relevant products for growers worldwide. The Under Current® is just one example of our dedication and commitment to quality.

While using the Under Current® you will enjoy the benefits of increased efficiency, reduced maintenance and larger overall yields... just to name a few.

Your comments are important to us because they help us provide the best service in the industry. So please don't hesitate to drop us a line via phone, email, web or social media.

Again, thank you for your purchase.

GROWER SUPPORT

We want every Under Current® grower to experience outstanding results and huge yields. Your success is our success!

We have a unique team of seasoned growers and problem solvers with years of experience in hydroponics and traditional growing techniques. We offer expert grower support and will do our very best to troubleshoot your issues, big or small.

If you have any questions concerning our products or need help with your grow, please contact our Tech Support department in one of the following ways:

Online: Fill out our Tech Support form @ cch2o.com

Email: Send us an email describing your issue tech@cch2o.com

INSTRUCTIONS OVERVIEW

The Under Current Assembly Instructions are broken into 6 phases. Each phase outlines an important step in the overall system setup. By closely following these instructions you will ensure your system is properly installed and ready to #GROWTREES

1. Drain Out Kit
2. Re-Circulation System
3. Air Pump Bank
4. Aeration Manifold
5. System Initiation
6. Planting

PAGE

UN-PACKING

3-4

Parts Overview

ASSEMBLY

5-12

Phase 1: Drain Out Kit

13-25

Phase 2: Re-Circulation System

27-30

Phase 3: Air Pump Bank

31-38

Phase 4: Aeration Manifold

39

Phase 5: System Initiation

40

Phase 6: Planting

RESERVOIR AND CHILLER INSTALLATION

41

Top-Off Reservoir Installation

42

Water Chiller Installation

SYSTEM MAINTENANCE

43

Draining & Cleaning the System

44

Maintenance & Disposal

BULKHEAD INSTALLATION/BONELESS CUT CHART

45

Bulkhead Installation Instructions

46

Boneless Manifolds Cut Chart

CCH2O RECOMMENDATIONS & FAQ'S

47

Cultured Solutions Feeding Schedule

48

General Recommendations

49-50

Frequently Asked Questions

WARRANTY

51

Current Culture H2O Limited 3-Year Warranty



PARTS

**Not all parts shown are included with every system. Reference the Pull Sheet included with your system for a full parts list.



EPICENTER



MULTI MOD GROWTH MODULE



UNISEALS



THREAD TAPE



DELIVERY MANIFOLD



RETURN MANIFOLD



JOINT



CCH20 BULKHEAD FILTER



CCH20 BULKHEAD WRENCH



MANIFOLD CRUTCH KIT



RETURN PUMP



PUMP KIT (SM, MED, LRG)



WYE KIT



RETURN HOSE



CCH20 ADD BACK KIT



EPI STEM KIT



FLOAT VALVE KIT



RESERVOIR ADAPTER KIT



CCH20 LID 5.5"



CCH20 NET POT 5.5"



**CCH20 AIR FLOW
REGULATOR**



AIR PUMP



AIR PUMP INLET TEE



AIR SUPPLY HOSE



AERATION JOINTS



AERATION BLUNT



AERATION MANIFOLD FITTINGS



AIR HOSE LEAD



AIR STONE KIT



DRAIN OUT JOINT



DRAIN OUT JOINT SHORT



DRAIN OUT EPI JOINT



DRAIN OUT BLUNT



DRAIN OUT VALVE

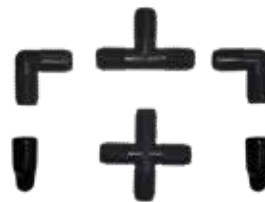

**DRAIN OUT MANIFOLD
FITTINGS**



**CULTURED SOLUTIONS
GROWER'S PACK**



PHASE 1: DRAIN OUT KIT



KEEP ALL ITEMS IN BAGS!
Do not open any kits or intermingle any items that are shipped separately.



Some items may not be used, this is normal.

1. Unbox. Place all parts adjacent to grow area. Move items into grow area as needed.
 - a. Modules, Epicenter, Module Plug Kits
 - b. Manifolds, Joints, Bulkhead Filters
 - c. Pump Kit, Wye Kit, Epicenter Kit
 - d. Return Pump, Return Hose, Add Back Kit
 - e. Air Pump, AFR. Air Supply Kit, Aeration Manifold Components, Air Stone Kit
 - f. Lids and Net Pots

Move Growth Modules, Epicenter and Uniseals into grow area.

ALL GROWTH MODULES

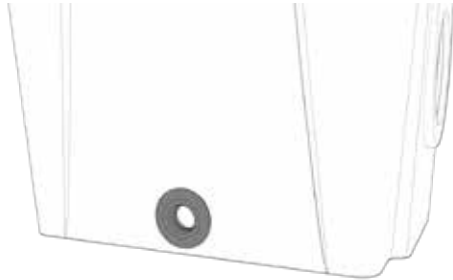

EPICENTER BASE

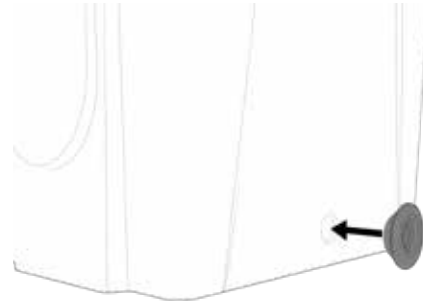

2. Install 3/4" Uniseals into the hole at the base of each GROWTH MODULE and EPICENTER.

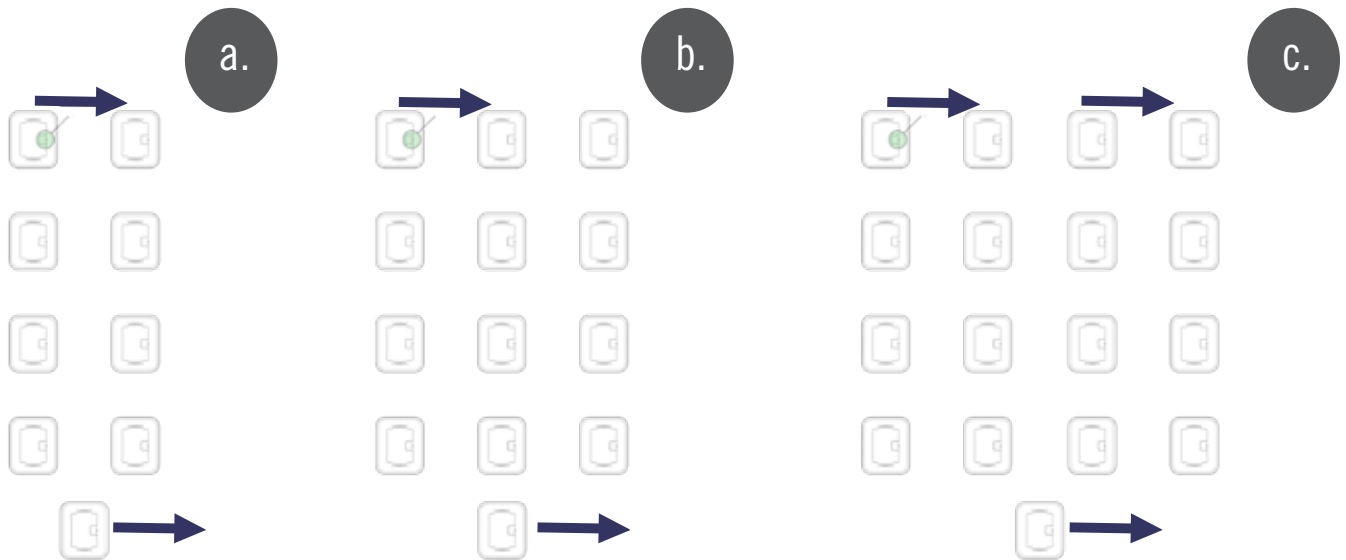

Align EPICENTER & ALL GROWTH MODULES with Uniseals/DRAIN OUT holes facing the same direction.



3. Layout GROWTH MODULES in your systems designated pattern, with EPICENTER at one end.

- a. Under Current (UC): Two Rows
- b. Under Current Evolution (UCE): Three Rows
- c. Under Current Double Barrel (UCDB): Four Rows



PHASE 1: DRAIN OUT KIT



Important Notes:

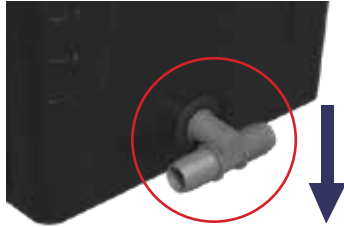

Drop Tees should always be oriented downward.



Drain Out Joints run parallel to module rows.



Drain Out Blunts run perpendicular to module rows.

2-Row



3-Row

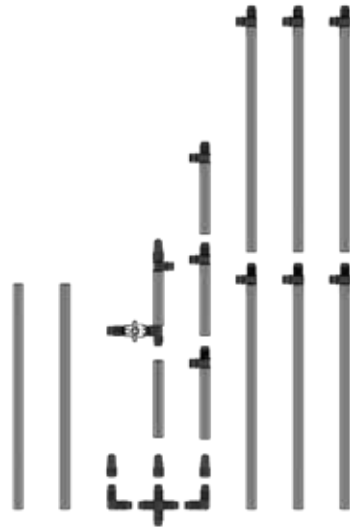

4-Row

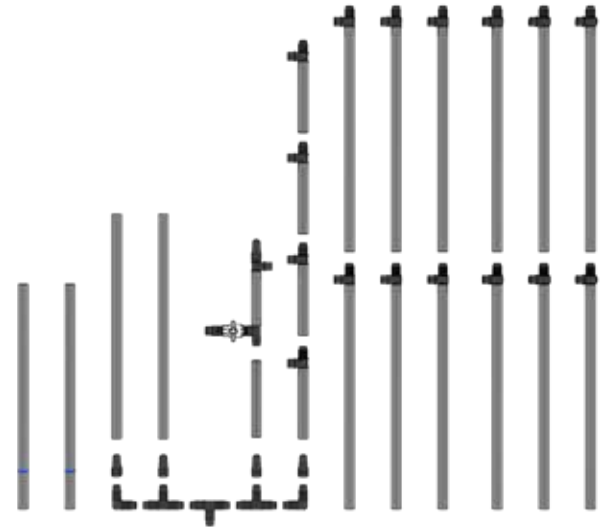

4. Layout all parts of the DOK System in area adjacent to grow area. Group all Hose in relative lengths.

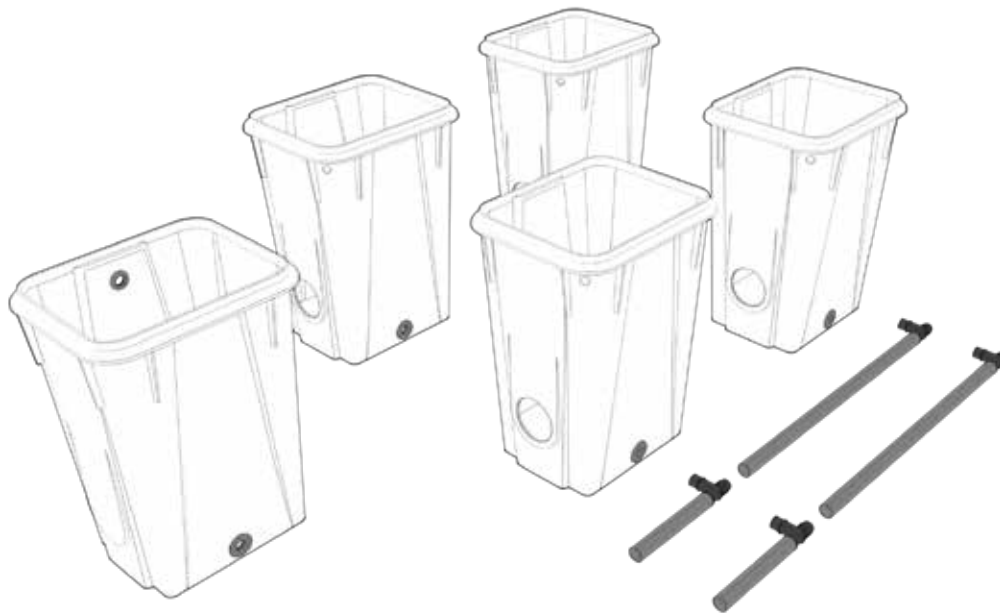

5. Lay out Joints along-side system, barbed end of Drop Tee facing Return Manifold

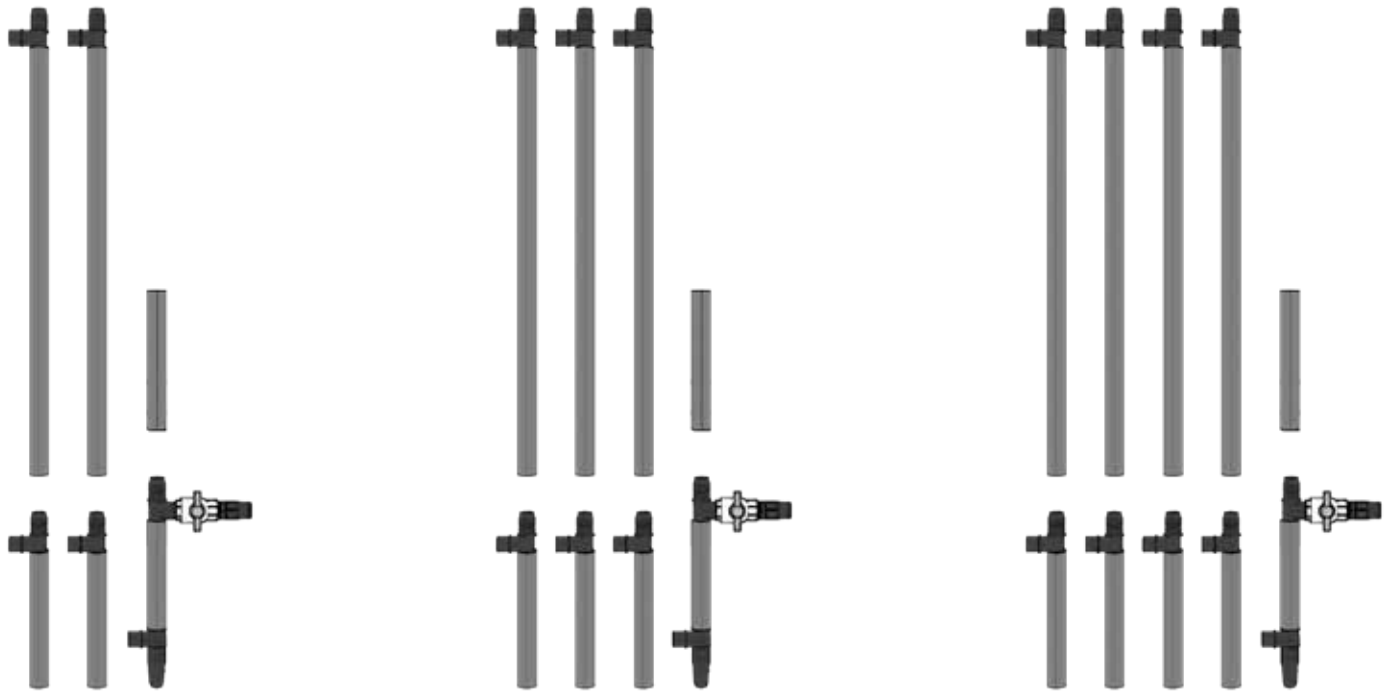

6. Layout a row of Joints for each corresponding row of the system being assembled. Example: Evolution has 3 rows, layout 3 rows of joints.

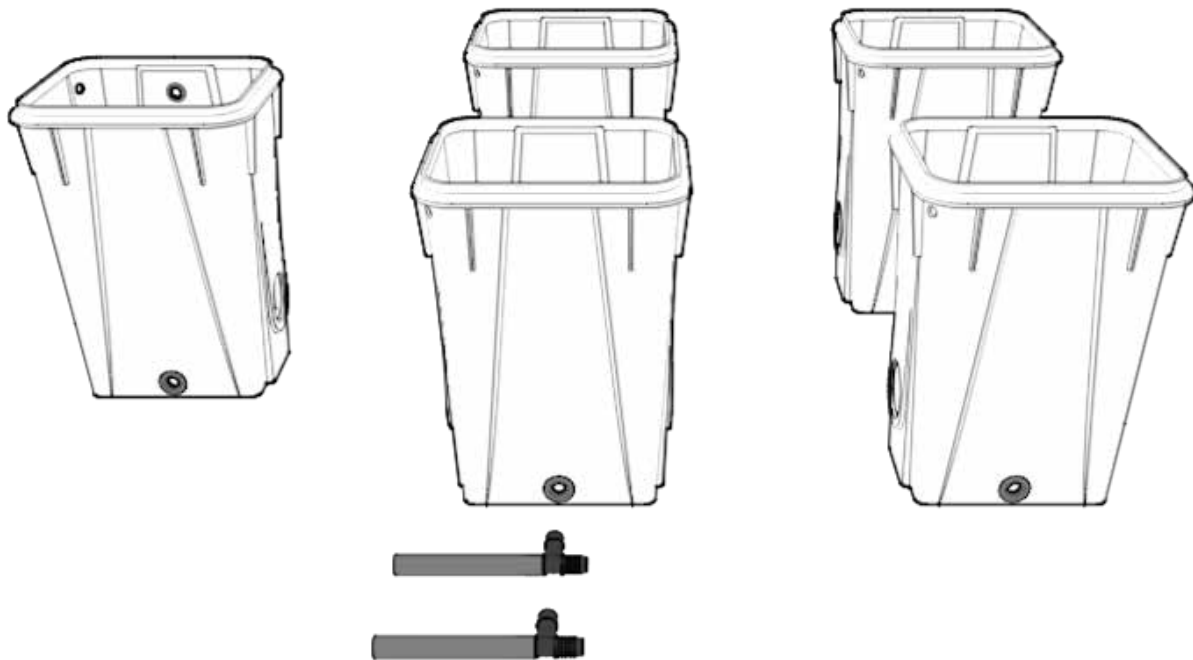

7. Begin each row of joints with a Drain Out Joint Short (shortest joints included in DOK Fitting Kit), which should be positioned nearest the Epicenter .



PHASE 1: DRAIN OUT KIT

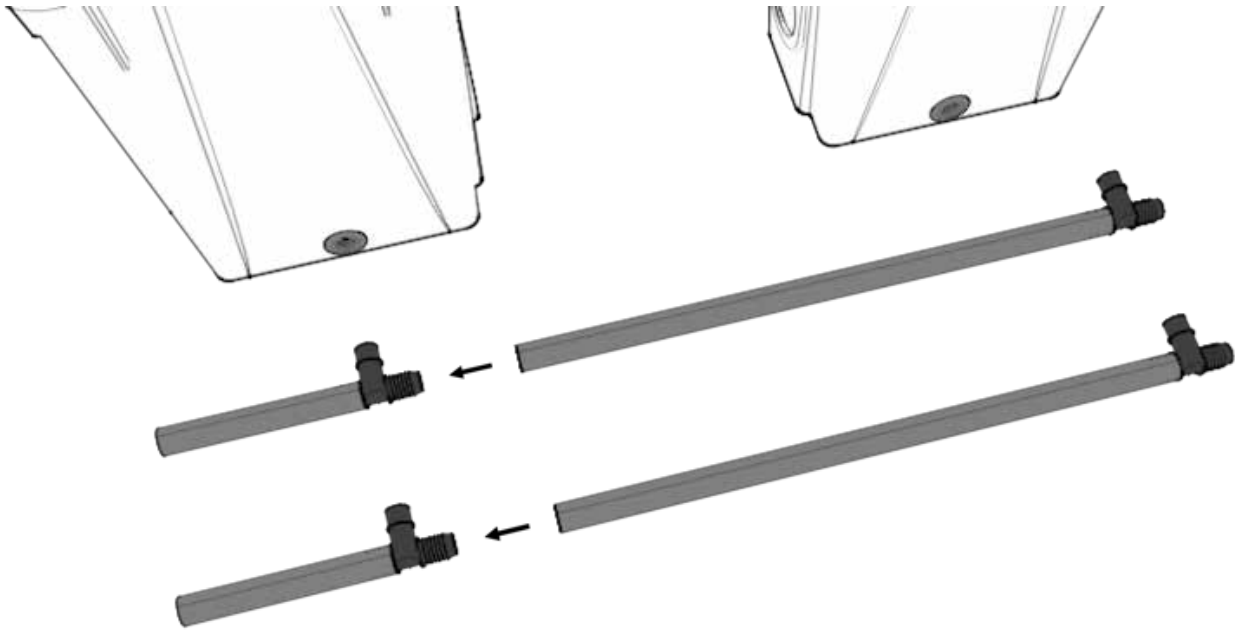

*BE CERTAIN THE PRINT ON THE DRAIN HOSE ALIGNED.

8. Attach all joints in series by pushing open end of drain hose onto the corresponding drop tee in series.

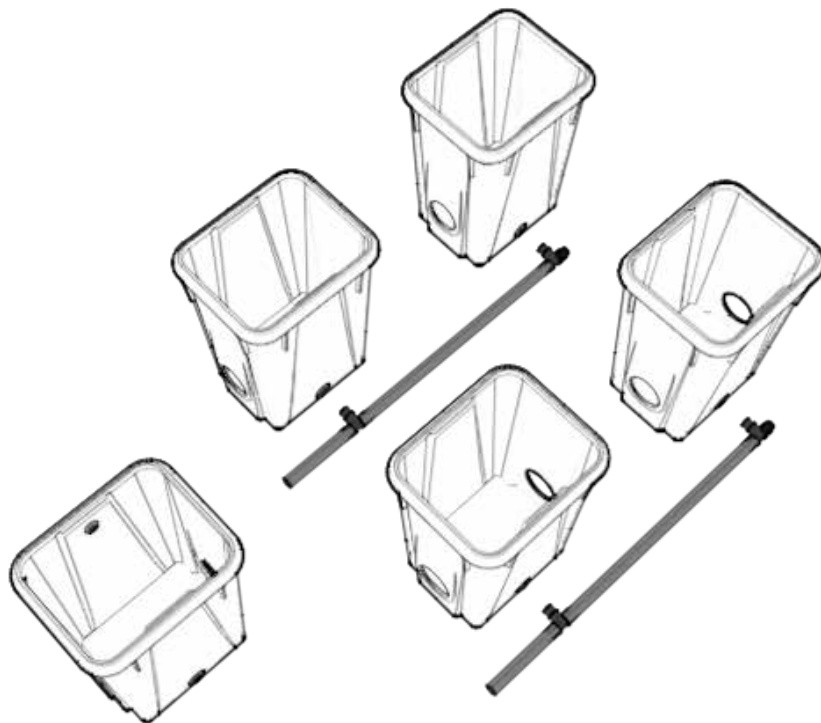

9. Move each row of aligned Drain Out Joints along-side the corresponding row of Growth Modules. Place on the Drain Well side of the row of Growth Modules.

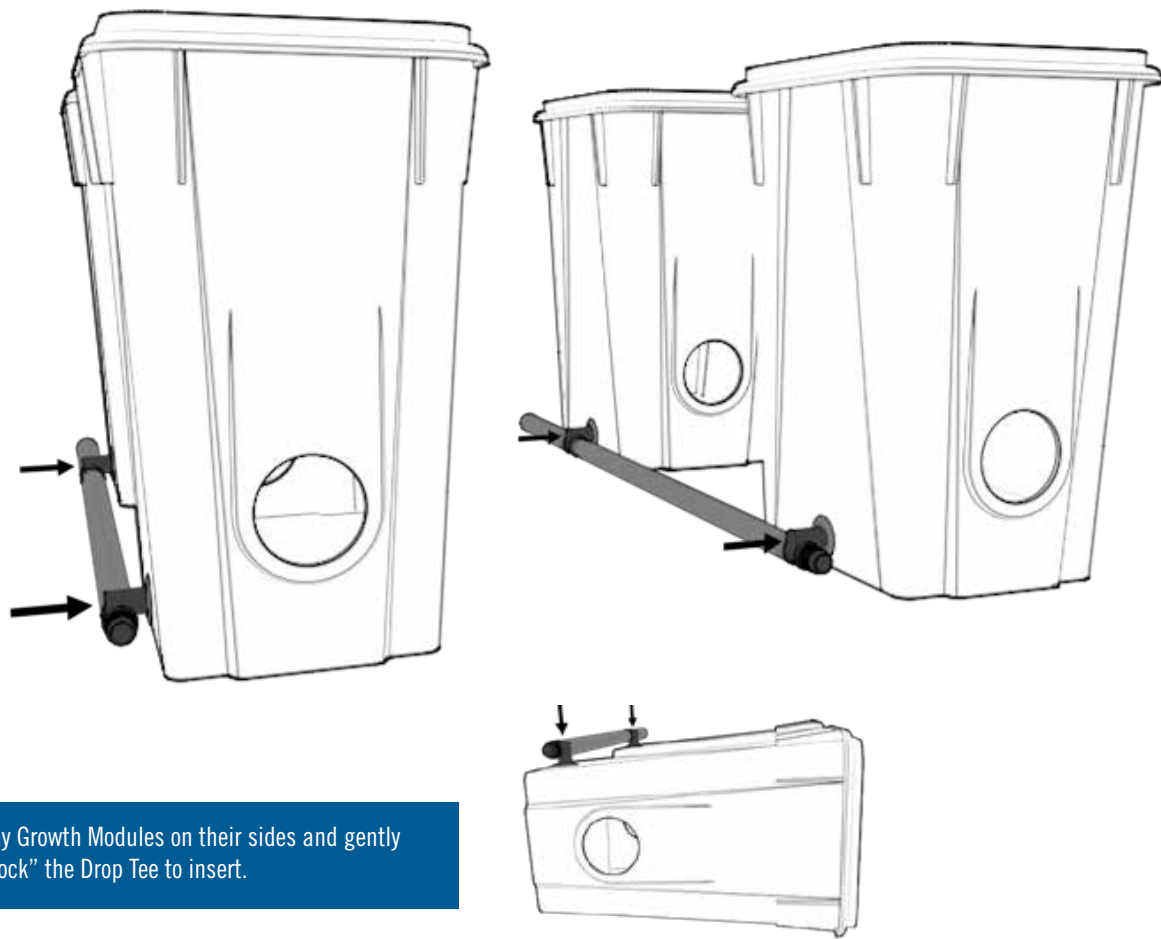

Lay Growth Modules on their sides and gently "rock" the Drop Tee to insert.

10. Install all Drop Tees into Uniseals at the base of the GROWTH MODULE. Push in until fully seated or until DROP TEE stops. Repeat for all Drop Tees and GROWTH MODULES.

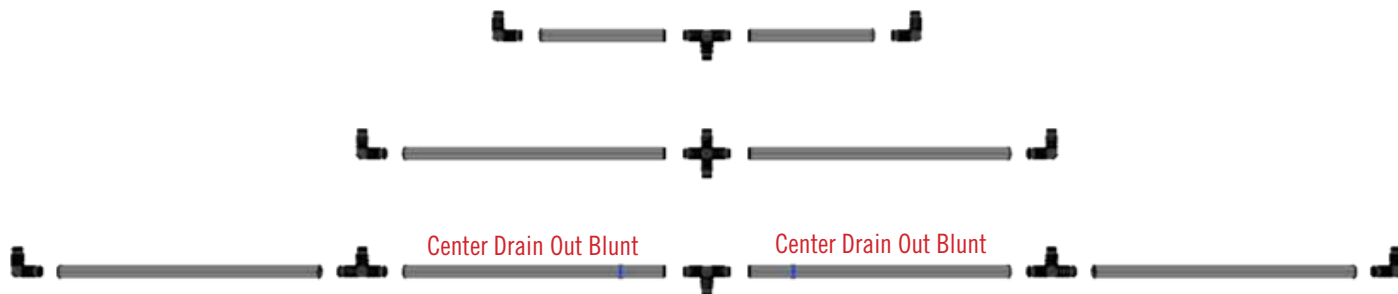

11. Layout Drain Out Blunts and 1" fittings (located in the Drain Out Fitting Kit) on the Delivery Manifold end of the system. Connect all parts to create the Drain Out Delivery Manifold.

a. *If assembling a Double Barrel (4 Row) system: (2) designated Center Drain Out Blunts (denoted with colored rubber band) will need to be connected with a 1" Tee and laid out on the Delivery Manifold.



PHASE 1: DRAIN OUT KIT

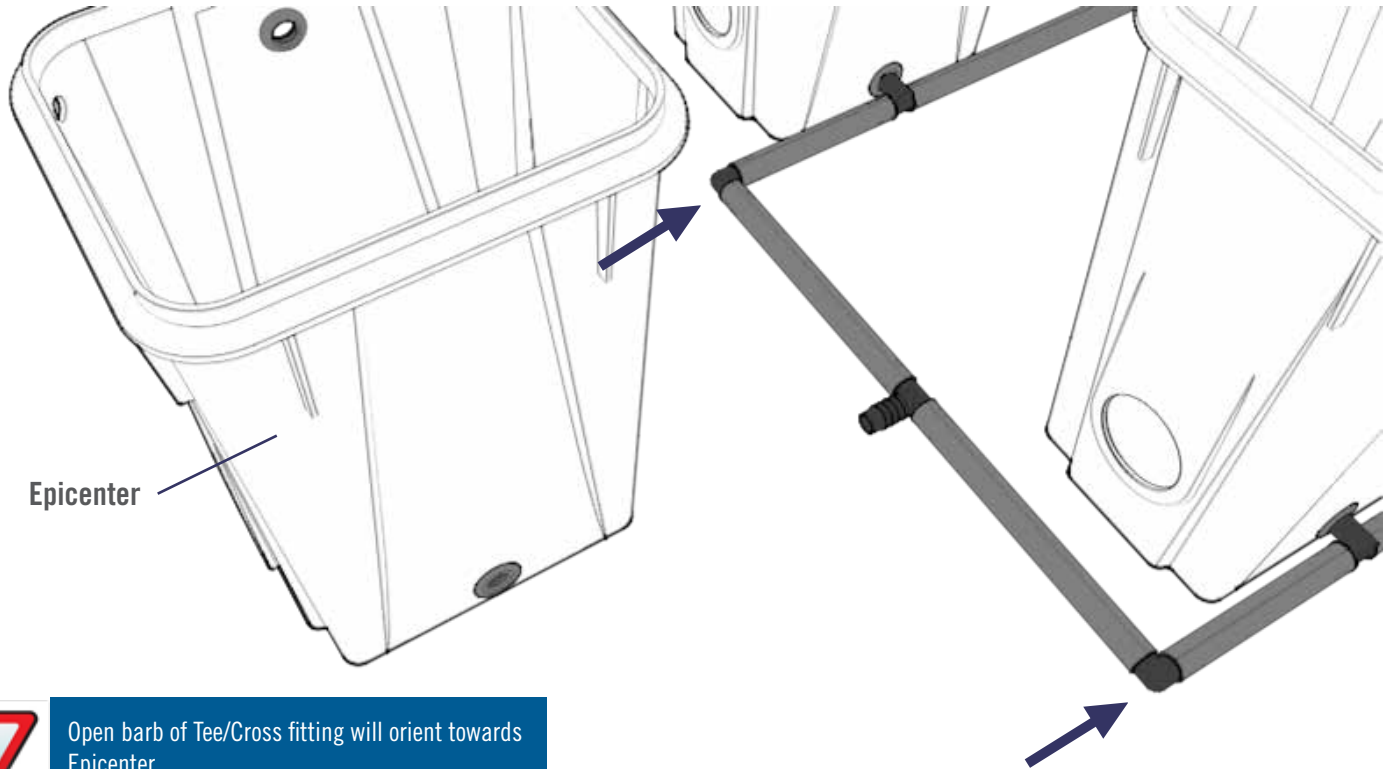

Open barb of Tee/Cross fitting will orient towards Epicenter.

12. Install the Drain Out Delivery Manifold to the corresponding Drain out Joints.

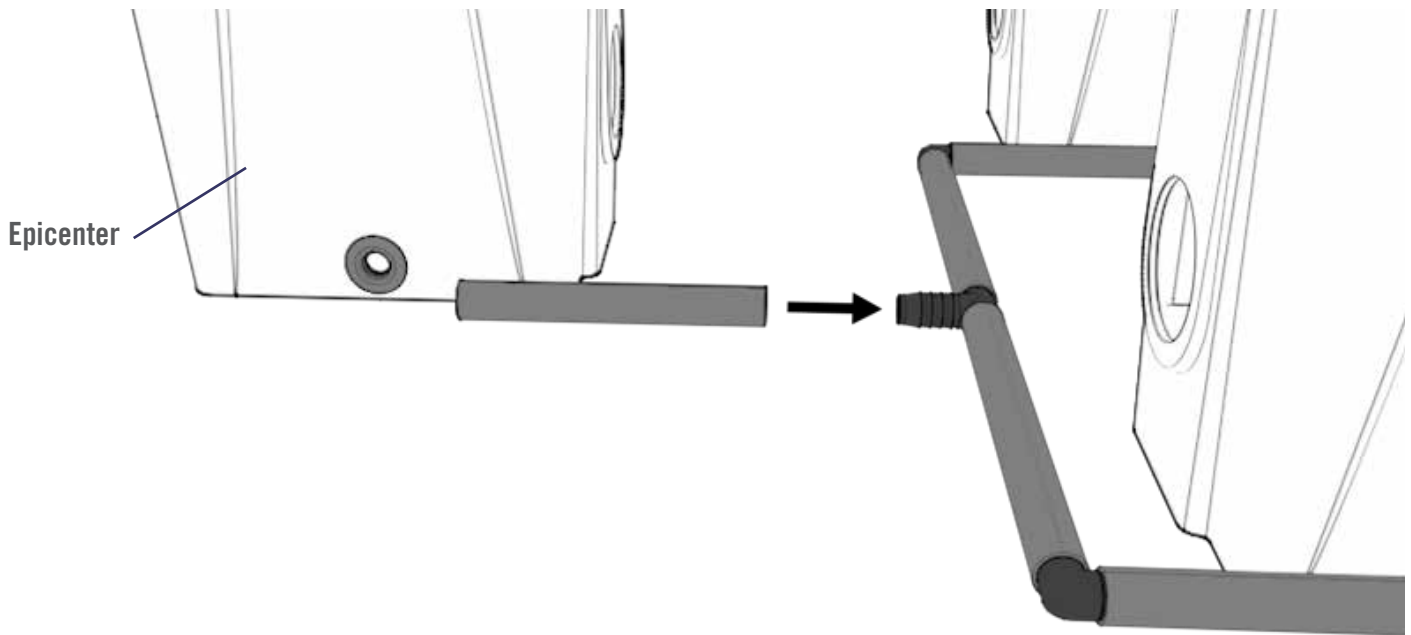

13. Attach the Epi Joint (located in DOK valve kit) to the open barb on Tee/Cross fitting on the delivery side of the DOK manifold. Pick one:

- a. Short – 8 gallon
- b. Long – 13 gallon

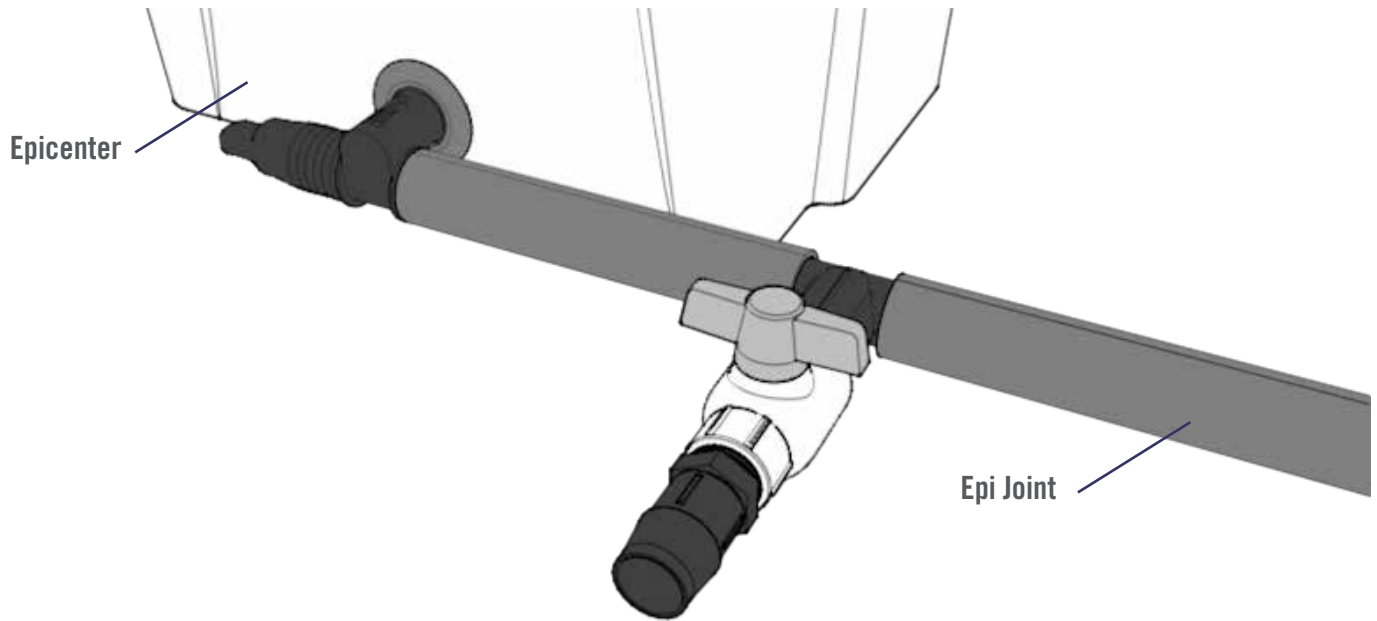

14. Install the DOK Valve Assembly (with attached Drop Tee) onto the Epi Joint. Install the Drop Tee into the Uniseal at the base of the Epicenter.

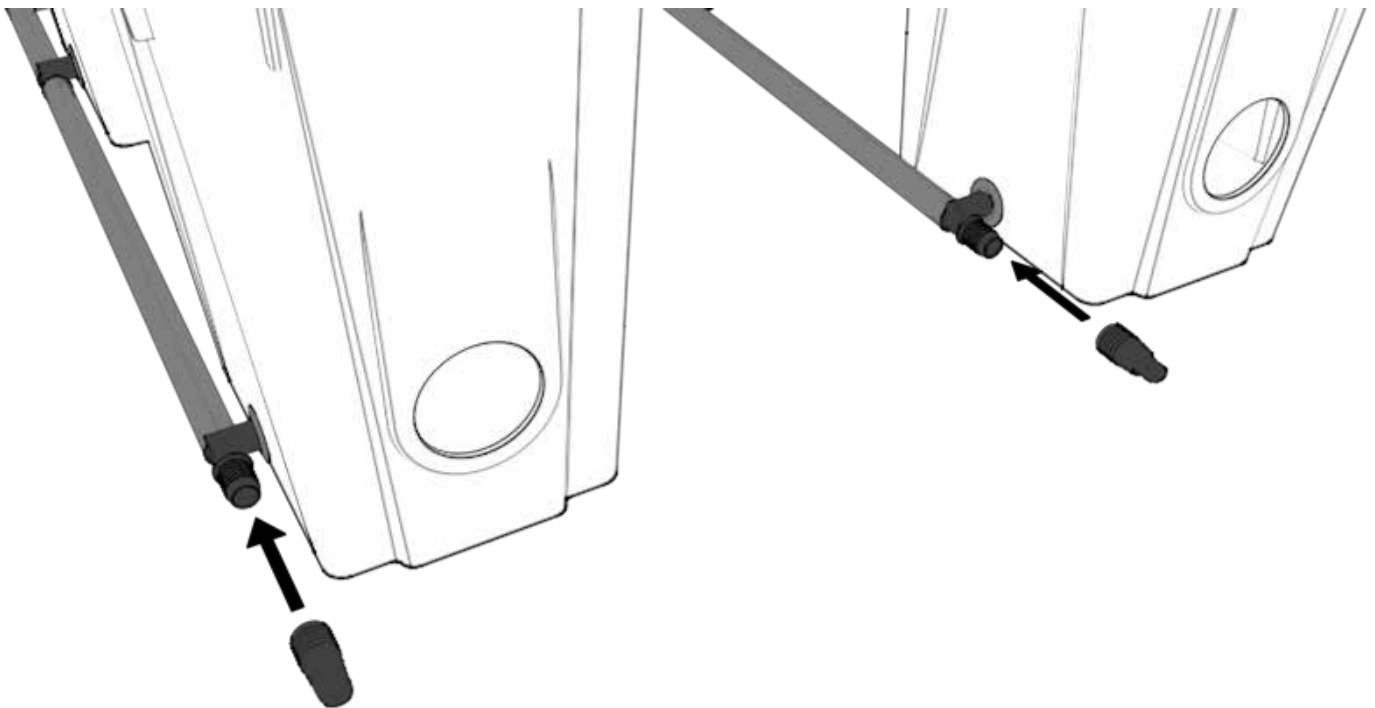

15. Install 1" caps on barbed ends of Drop Tees at end of system near return manifolds.

Drain Out Kit is Complete!



PHASE 2: RE-CIRCULATION SYSTEM

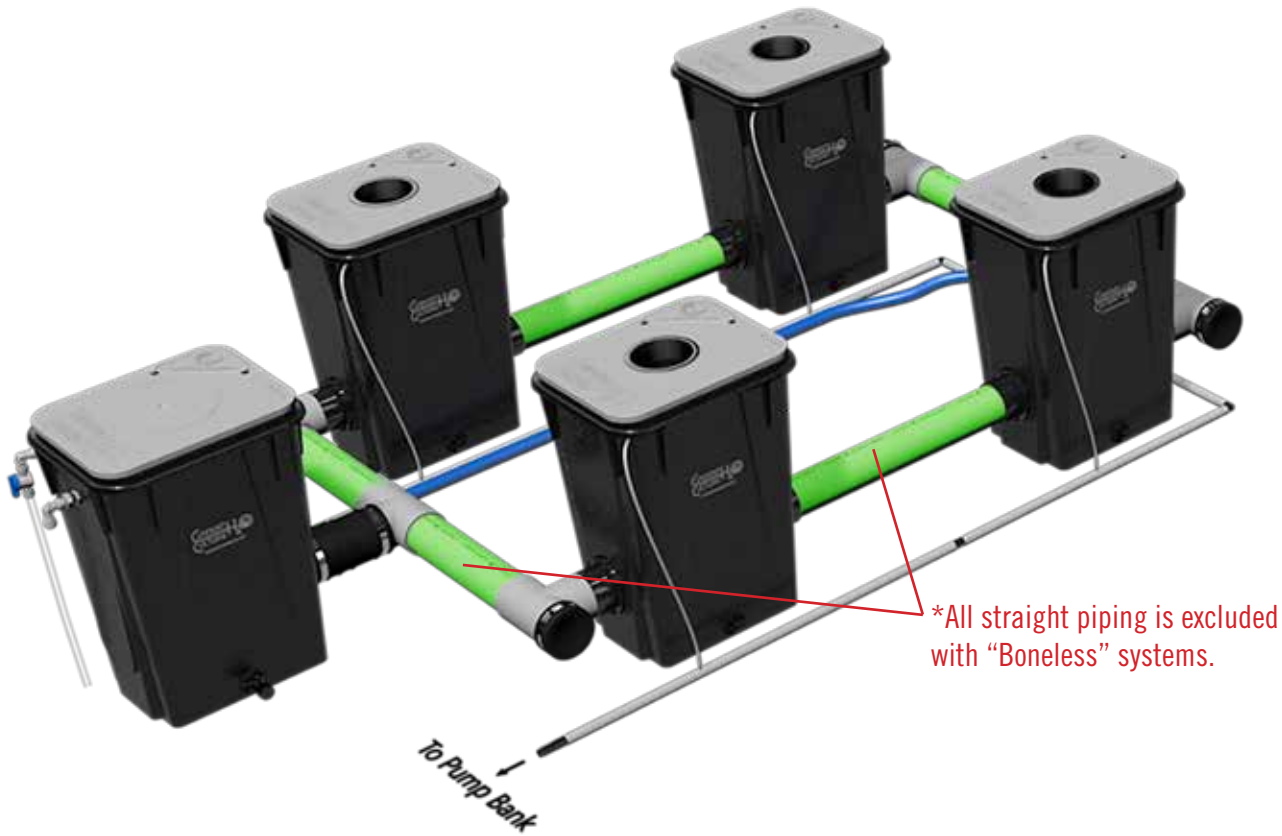
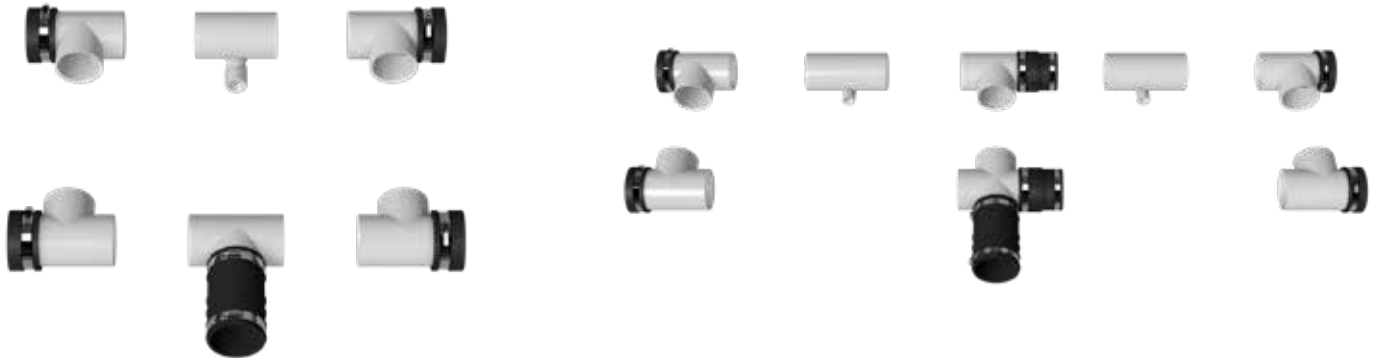

If assembling a BONELESS system, follow BULKHEAD instructions included in BONELESS KIT. See BONELESS CUT CHART on page 46.

1. If assembling standard system, carry on with instructions.

Move all Joints, Manifolds and Bulkhead Filters into grow area.

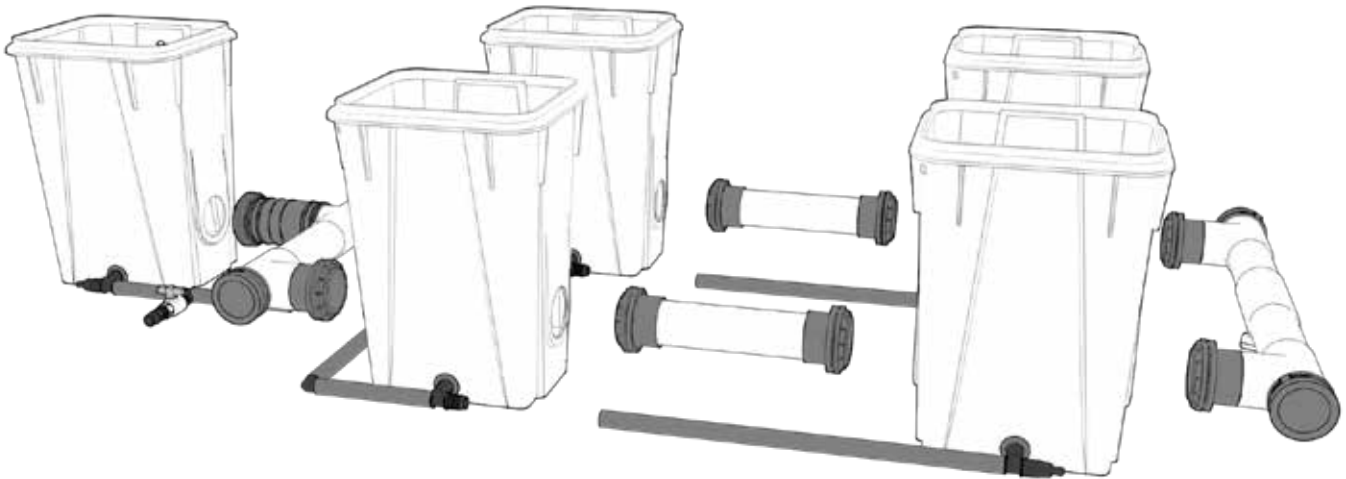

Do not remove all bulkhead nuts, only remove the nuts on the joint or manifold you are about to install. Do not remove gasket from bulkhead when removing nut.

2. Layout all Joints and Manifolds relative to placement in system alongside corresponding GROWTH MODULES.

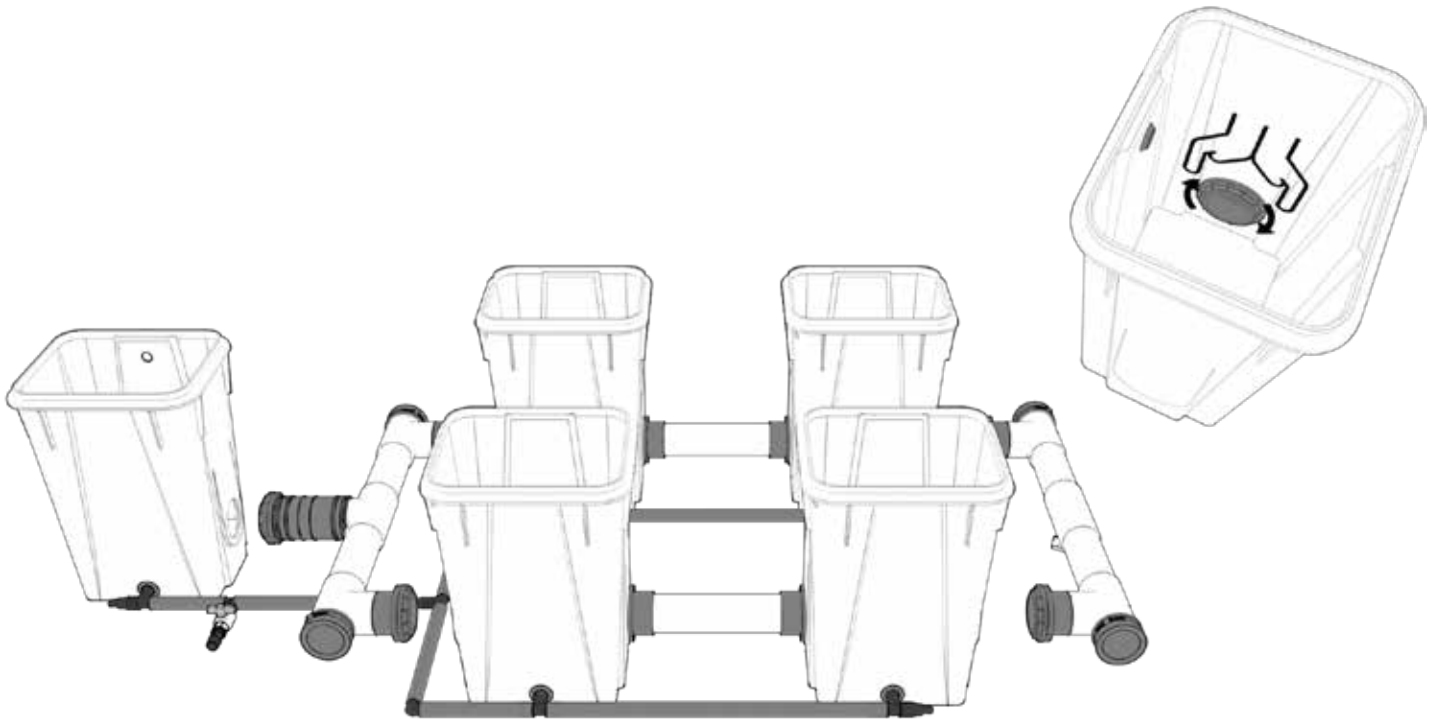

3. Connect all GROWTH MODULES with JOINTS.

- Seal the bulkhead in the hole so that the gasket is flat and tight against the outside of the module wall.
- Install the Bulkhead Nut on the inside of the Growth Module, hand-tighten.



PHASE 2: RE-CIRCULATION SYSTEM

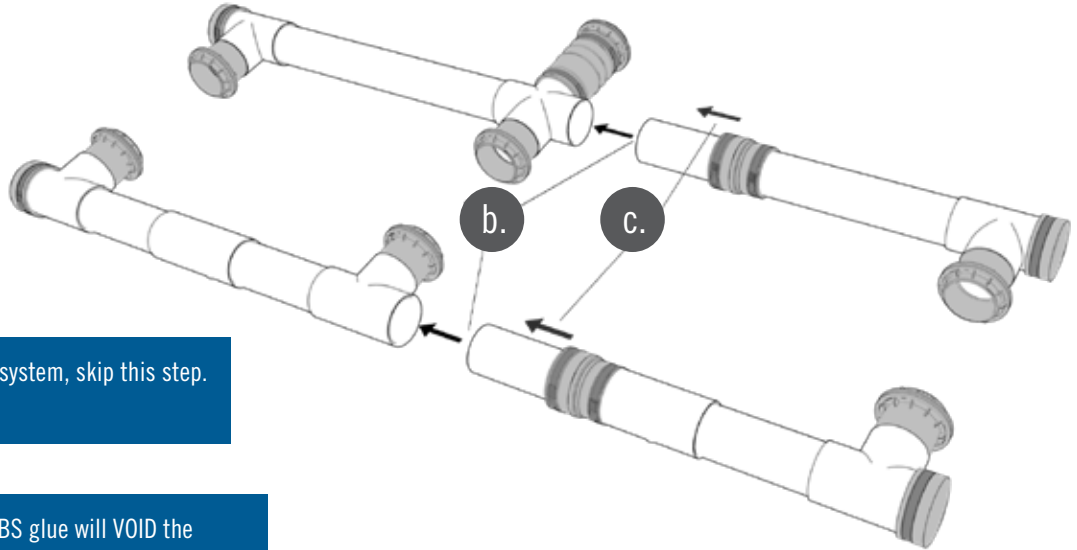

If assembling a 2-row system, skip this step.



CAUTION: Using PVC/ABS glue will VOID the warranty on your DELIVERY/RETURN MANIFOLDS.

4. Assemble Delivery Manifold for 3-Row (Evolution) and 4-Row (Double Barrel) Systems:
 - a. Loosen the small clamp on the rubber sleeve.
 - b. Fully seat the pipe into the female tee socket.
 - c. Slide sleeve over to fully cover socket.
 - d. Align all Bulkheads horizontally to ensure proper orientation to Growth Modules.
 - e. Once orientation is achieved, tighten clamp screws on both sides of rubber sleeve.

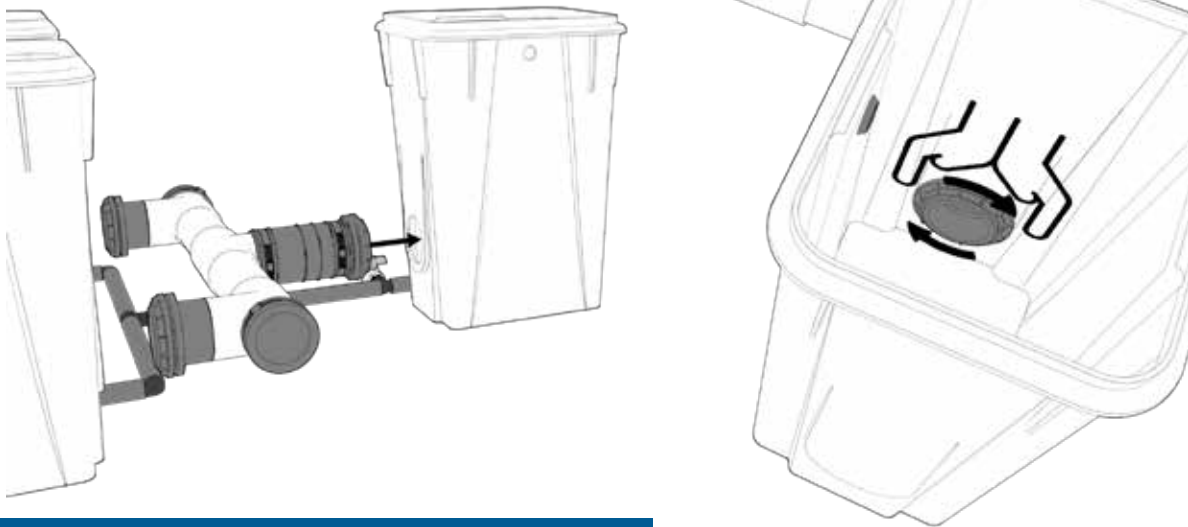

Visually inspect the outside connection for gaps, if you see any gaps loosen and re-seat the Main Bulkhead Body.

5. Install DELIVERY MANIFOLD into EPICENTER.
 - a. Insert the center Bulkhead of the DELIVERY MANIFOLD into the EPICENTER, seat the bulkhead in the hole so that the gasket is flat and tight against the outside of the module wall.
 - b. Install the Bulkhead Nut on the inside of the EPICENTER and hand-tighten.

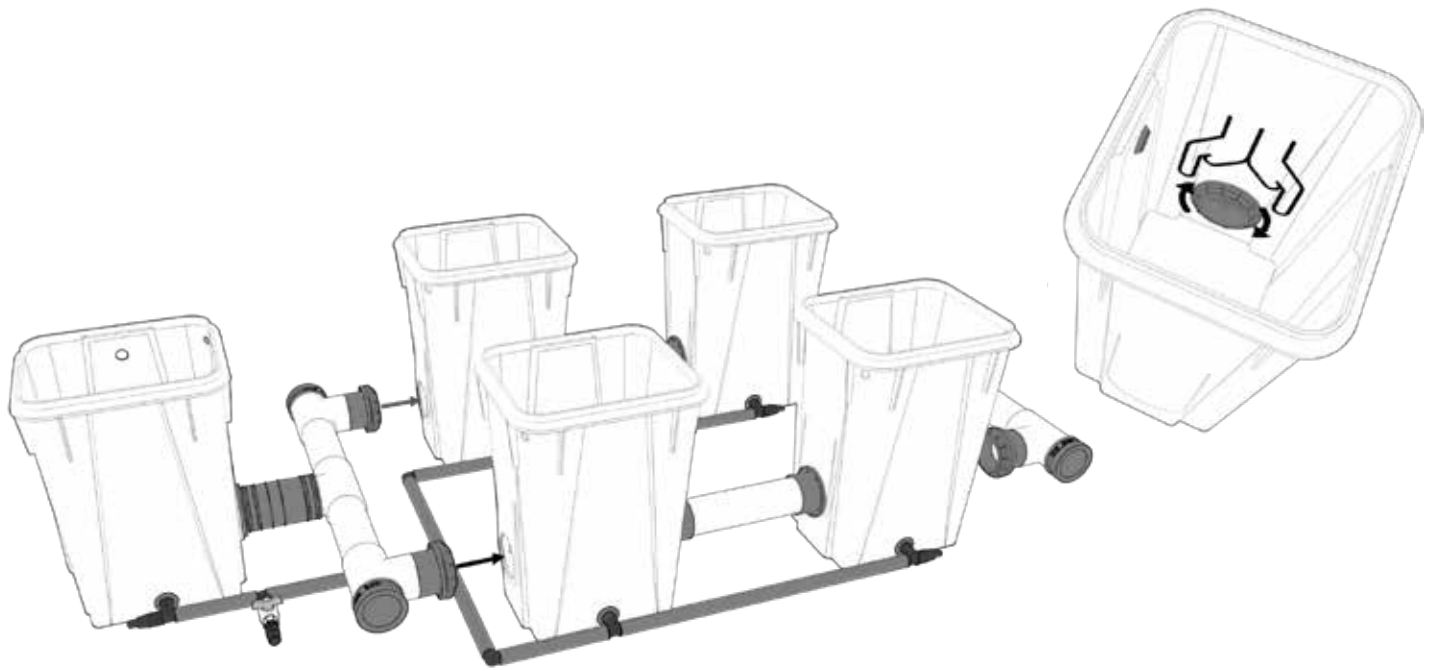

6. Connect DELIVERY MANIFOLD to first row of GROWTH MODULES.
 - a. Insert the Bulkhead of the DELIVERY MANIFOLD into the first row of GROWTH MODULES, seat the bulkhead in the hole so that the gasket is flat and tight against the outside of the module wall.
 - b. Install the Bulkhead Nut on the inside of the Growth Module, hand-tighten.

Move Pump Kit, Epicenter Kit and Wye Kit (only for 3-row and 4-row systems) to grow area.

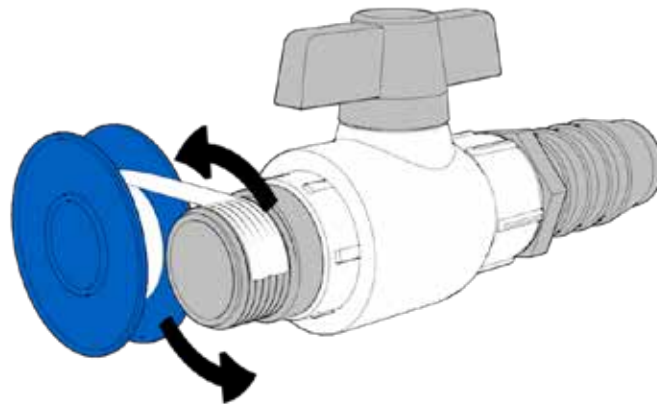

Do not excessively tape (no more than 3 revolutions) or over-tighten the threaded nipple.

7. Use Thread Tape (located in Instructions Kit) on male nipple of 1" Valve (Located in PUMP KIT).



PHASE 2: RE-CIRCULATION SYSTEM

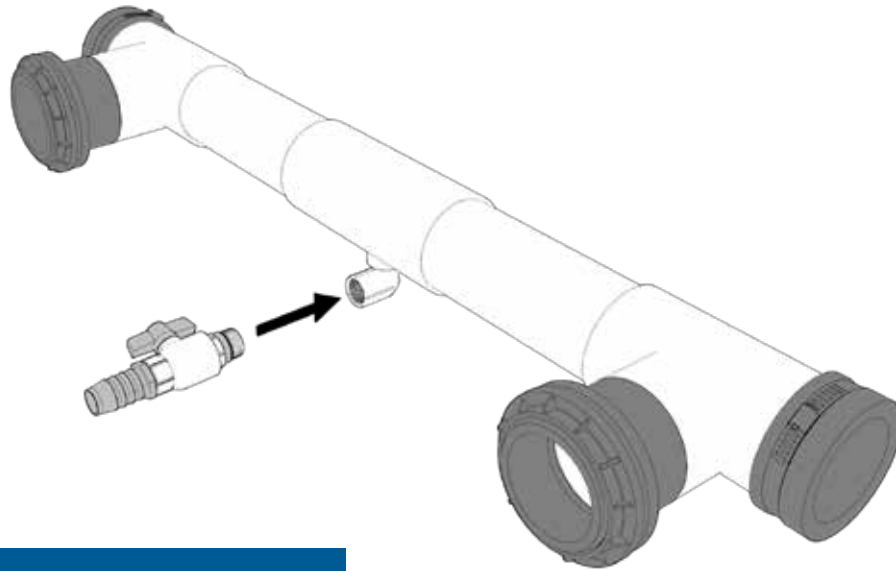

Do not excessively tape (no more than 3 revolutions) or over-tighten the threaded nipple.

8. Install 1" valve into the 1" elbow on the bottom of the RETURN MANIFOLD. Blue valve handle should be facing up.
 - a. *For Evolution (3-row) or Double Barrel (4-row) systems repeat these steps for the second valve. (Located in WYE FITTING KIT)

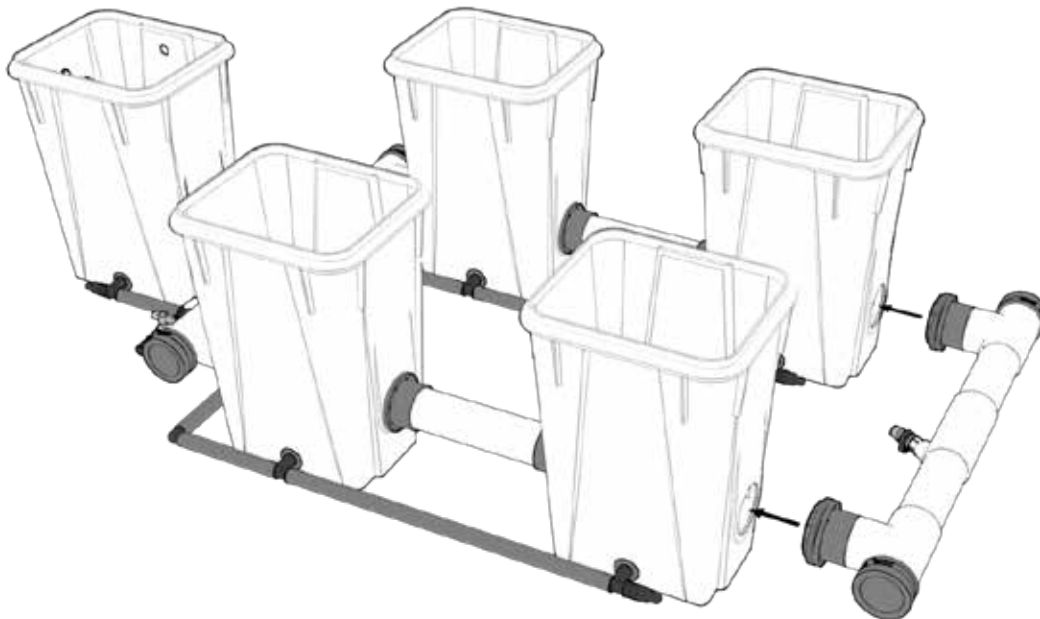

9. Install RETURN MANIFOLD(S) to last row of GROWTH MODULES. 1" Valve Assembly on Return Manifold should be oriented in a downward position. Install the Bulkhead Nut on the inside of the Growth Module, hand-tighten.
 - a. *For Double Barrel Systems repeat this step for the second RETURN MANIFOLD.

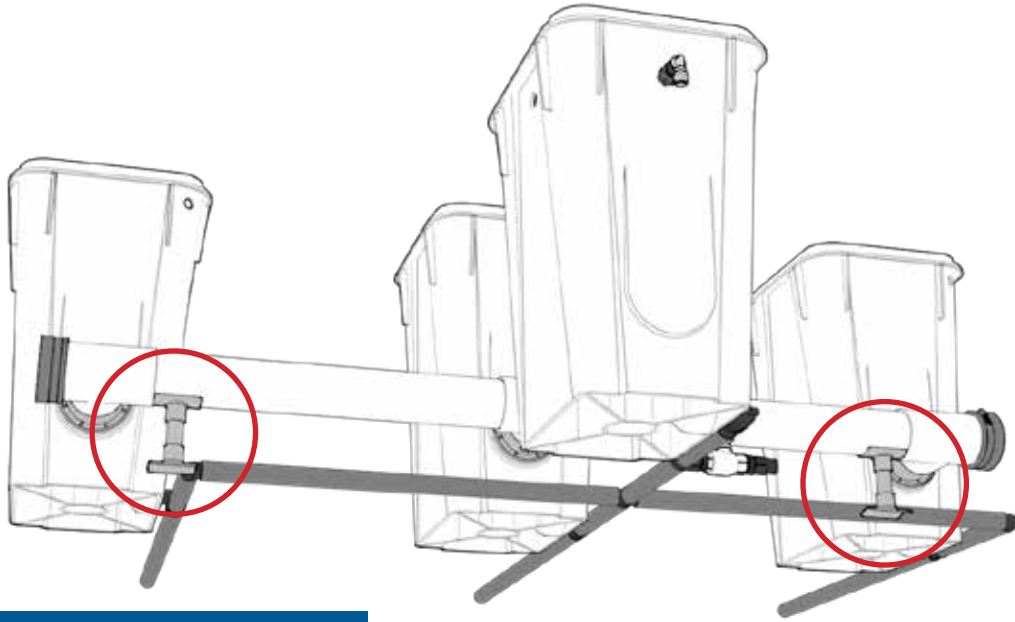

For 8-gallon systems skip this step.

10. For 13 Gallon Systems place MANIFOLD CRUTCH(S) under DELIVERY MANIFOLD piping at both corners.

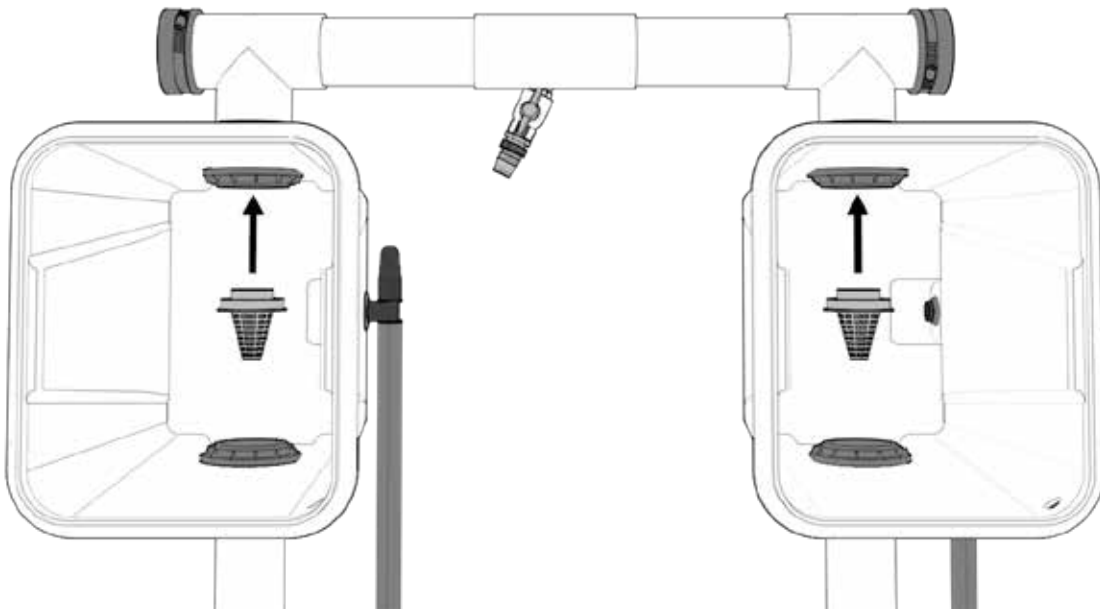

11. Install BULKHEAD FILTERS inside the last row of GROWTH MODULES into RETURN MANIFOLD BULKHEADS.



PHASE 2: RE-CIRCULATION SYSTEM

Move RETURN PUMP, 1" RETURN Hose and Add Back Kit to grow area.

12. Remove RETURN PUMP from box. ****Discard stock filter included with RETURN PUMP.**

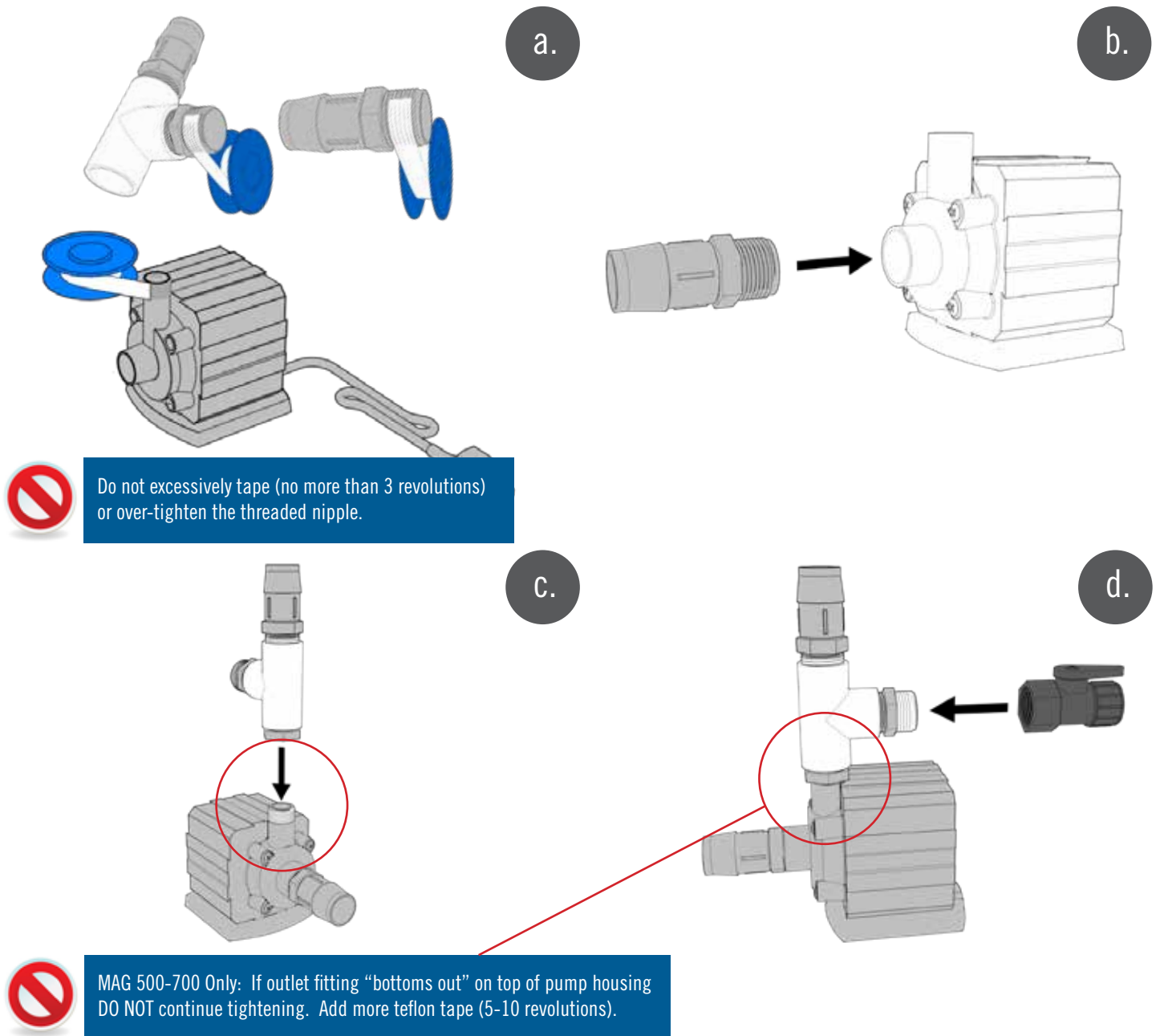

13. Install RETURN PUMP fittings (Located in PUMP KIT).

- Tape ALL Male Fittings and Pump Outlet.
- Install PUMP INLET fitting into RETURN PUMP inlet.
- Install PUMP OUTLET TEE FITTING onto RETURN PUMP outlet.
- Install BYPASS VALVE on to PUMP OUTLET TEE FITTING. Make sure valve is closed and cap is tightened.

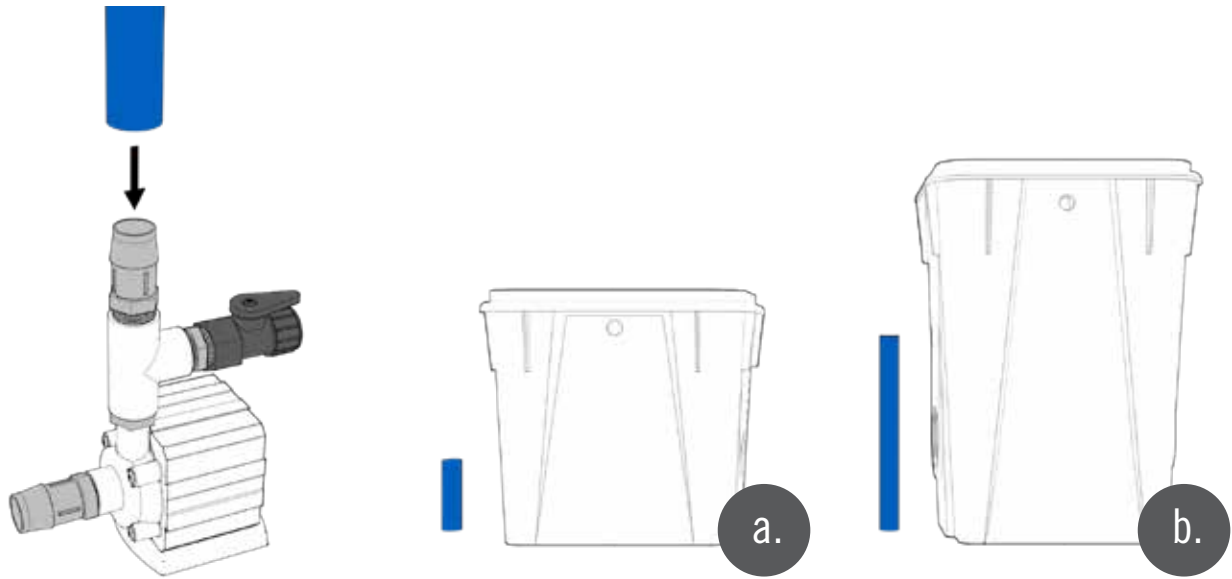

14. Install Straight Section of OUTLET HOSE (Located in PUMP KIT) onto Return PUMP OUTLET Tee Fitting.
a. If 8 Gallon System use Shorter Hose
b. If 13 Gallon System use Longer Hose

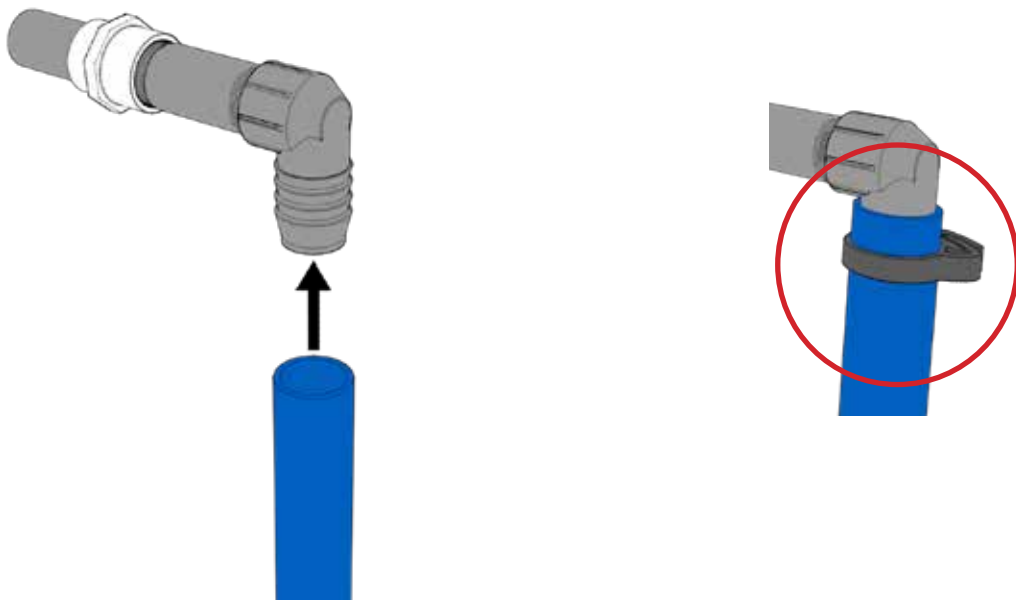

15. Install EPI INLET STEM (located in EPICENTER KIT) onto OUTLET HOSE upright from Return PUMP OUTLET Tee Fitting. Install Click Clamps on ALL hose connections.



PHASE 2: RE-CIRCULATION SYSTEM

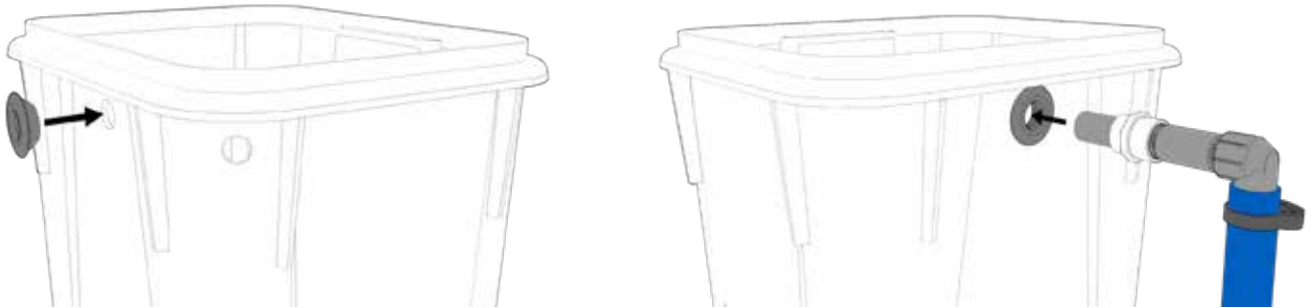

16. Install complete RETURN PUMP with EPI INLET STEM into Epicenter.
 - a. Install 3/4" Uniseals (Located in Epi Stem Kit) into the hole at the top of the EPICENTER.
 - b. Insert Pump Stem though upper Uniseal in the Epicenter. Be sure nipple on stem is fully inserted into Uniseal and bottomed out.

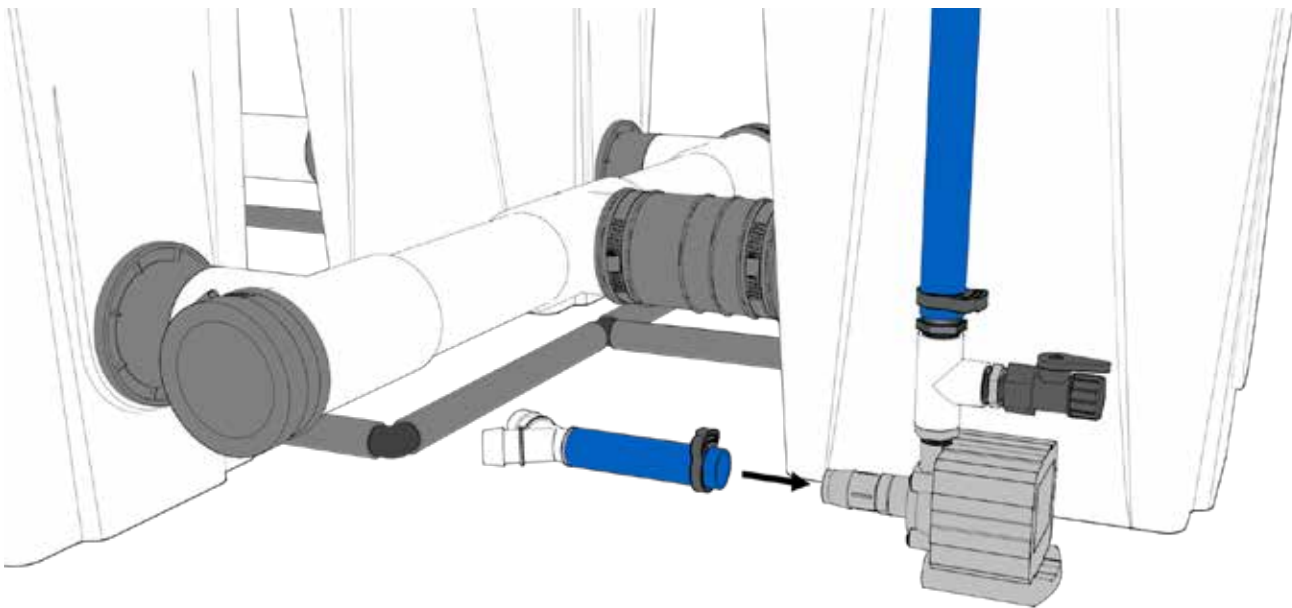

For 2-row systems skip this step..

17. Install Wye Fitting to barb on pump inlet.

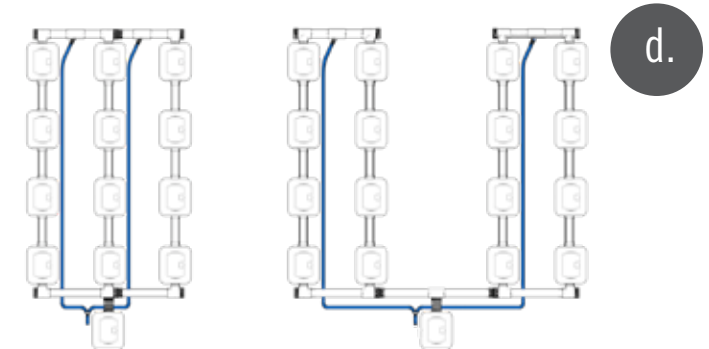
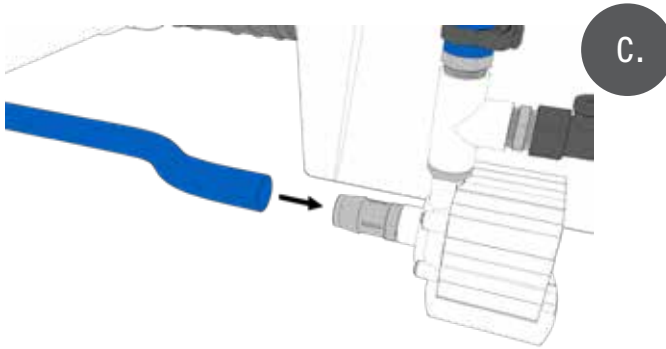
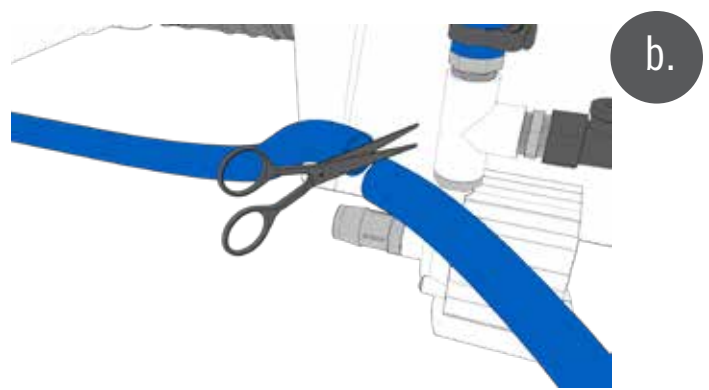
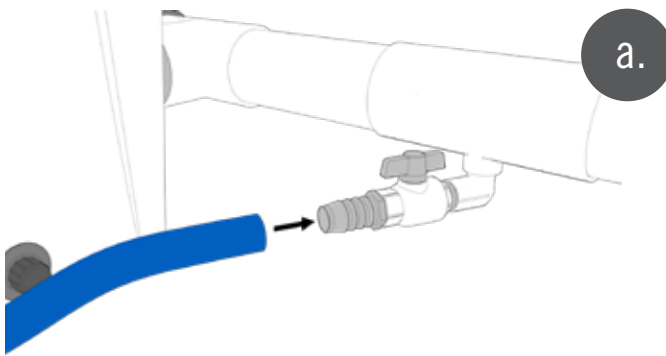

CAUTION: Measure twice before cutting hose.

18. Install RETURN HOSE(S).

- a. Attach 1" Return Hose to 1" Valve on Return Manifold.
- b. Run Return Hose to Return Pump, cut to length.
- c. Attach to RETURN Pump Inlet.
- d. * For 3-Row (Evolution) and 4-Row (Double Barrel) Systems repeat process for second Return Hose attach to Wye Fitting.

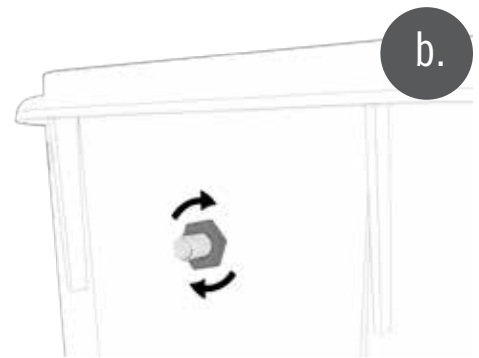
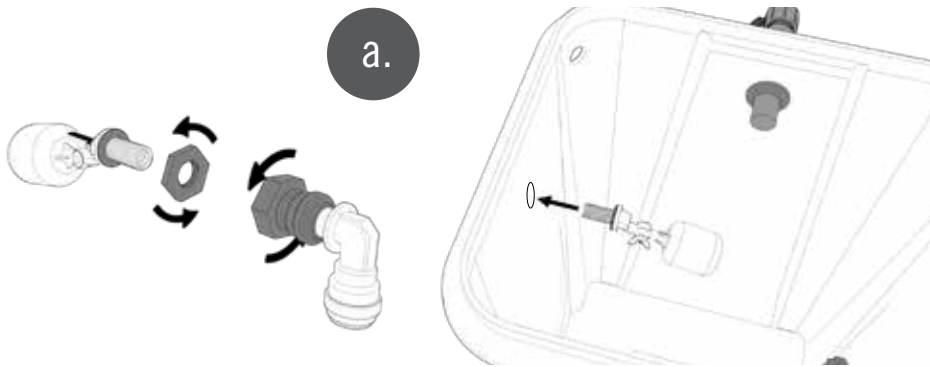

Make sure FLOAT VALVE is oriented correctly.



19. Install Float Valve (located in Epicenter Kit).

- a. Unscrew Nut from float valve.
- b. Install FLOAT VALVE into lower/central hole with rubber washer on inside EPICENTER. Secure with plastic nut, tighten nut down completely to ensure a good seal.
- c. Apply thread tape to male threads on float valve.



PHASE 2: RE-CIRCULATION SYSTEM

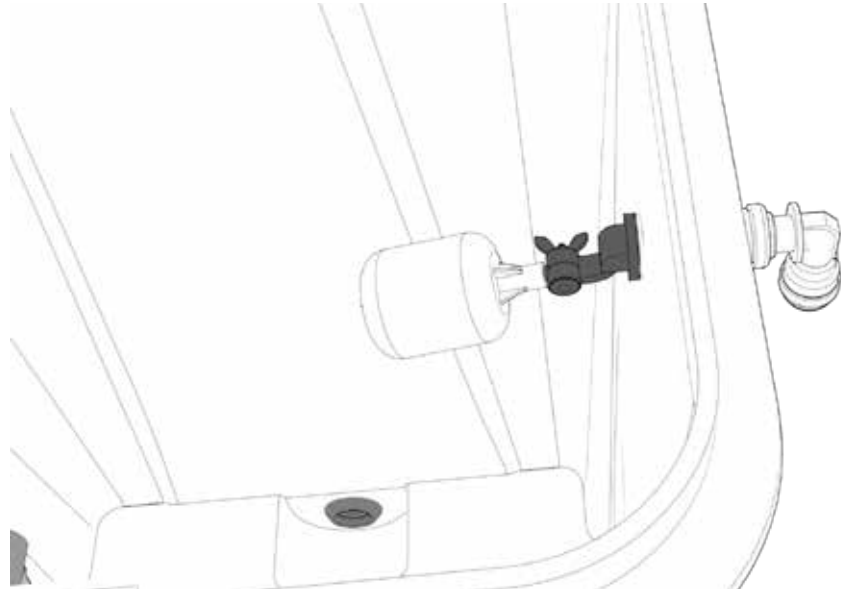

DO NOT adjust wing nut on Float Valve.

20. While holding FLOAT VALVE firmly in place. Screw on FLOAT VALVE QUICK CONNECT fitting (located in Epicenter Kit). Tighten until fitting no longer rotates. Orient the 1/2" Elbow downward. *See Page 35 for Reservoir Installation Instructions.

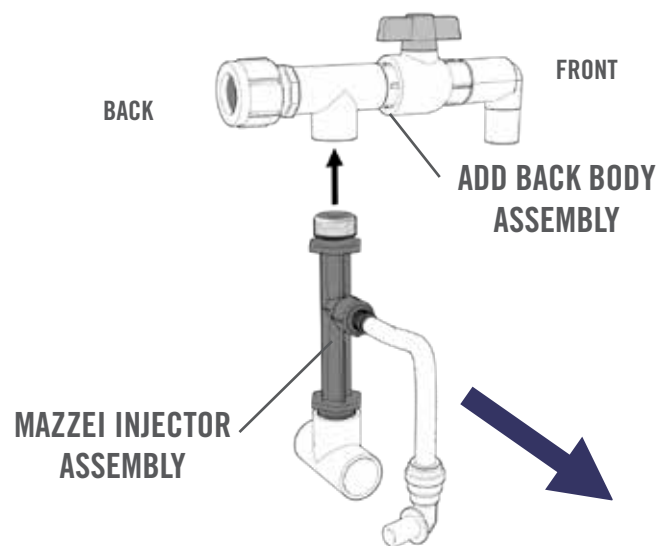

21. Assemble ADD BACK KIT

- Install Mazzei Injector Assembly into Add Back Body Assembly.
- Align tee perpendicular to valve. Orient 3/8" hose towards right side when looking at ABK from back to front.

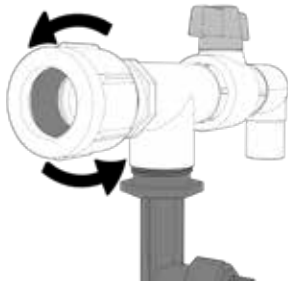

a.



b.



c.

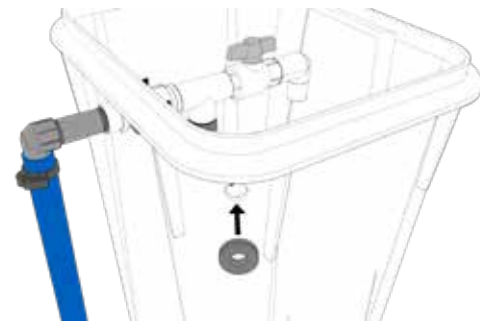

d.



e.



f.

22. Install Add Back Kit inside Epicenter.

- a. Loosen the female union on Add Back assembly. ***DO NOT REMOVE**
- b. Inside Epicenter: Slip the female union over the EPI INLET STEM. Ensure rubber gasket (inside union) is fitted over EPI INLET STEM nipple.
- c. Tighten the female union until the Add Back assembly is fully seated.
- d. Remove (from elbow) and install 3/8" Grommet into remaining hole in Epicenter.
- e. Insert 3/8" Stem Elbow (connected to 3/8" hose) through grommet.
- f. Outside Epicenter: Connect 3/8" Elbow (with Valve) to 3/8" Stem.



PHASE 2: RE-CIRCULATION SYSTEM



DO NOT OVER TIGHTEN.

23. Use the included BULKHEAD WRENCH to tighten all Bulkhead Fittings. 1/4 - 1/2 turn ONLY.

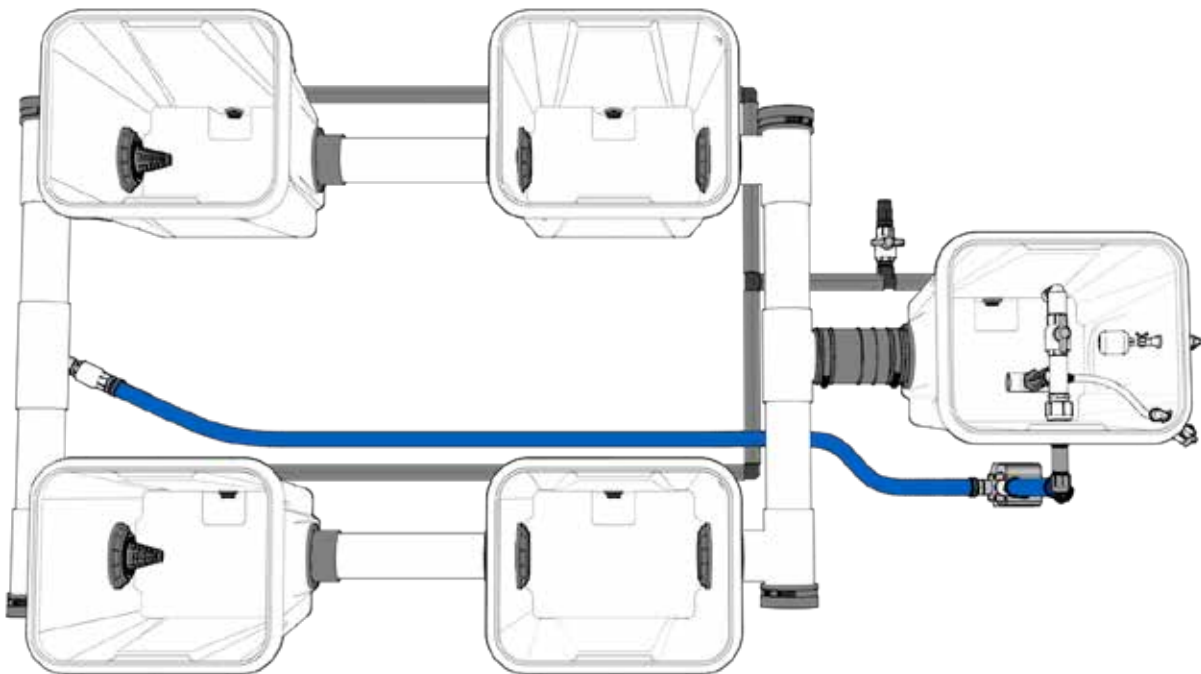

24. Inspect all system connections. Ensure that bulkhead gaskets are flush against module wall with NO gaps.

Re-Circulation System is Complete!



PHASE 3: AIR PUMP BANK



Air Pump Bank Location Guidelines

Before choosing the ideal location for the system's Air Pump Bank (APB) please consider the following:

- Make sure the area has adequate electrical service
- Locate the APB outside the grow area if possible
- Make sure the area is free of any potential electrical hazards
- Recommended mounted height:
 - o 60" off floor is ideal if mounted inside grow area
 - o 36" off floor is ideal if mounted outside grow area
- Make sure the area is properly ventilated
- Make sure the area is clean and free of dust/debris
- Distance from APB to system's Aeration Manifold:
 - o The APB should be located no further than 15ft. from the system's Aeration Manifold connection.
 - o **If further than 15ft., larger diameter delivery plumbing will be needed.*



Move Air Pump(s), Air Flow Regulator and Air Supply Starter Kit to grow area.

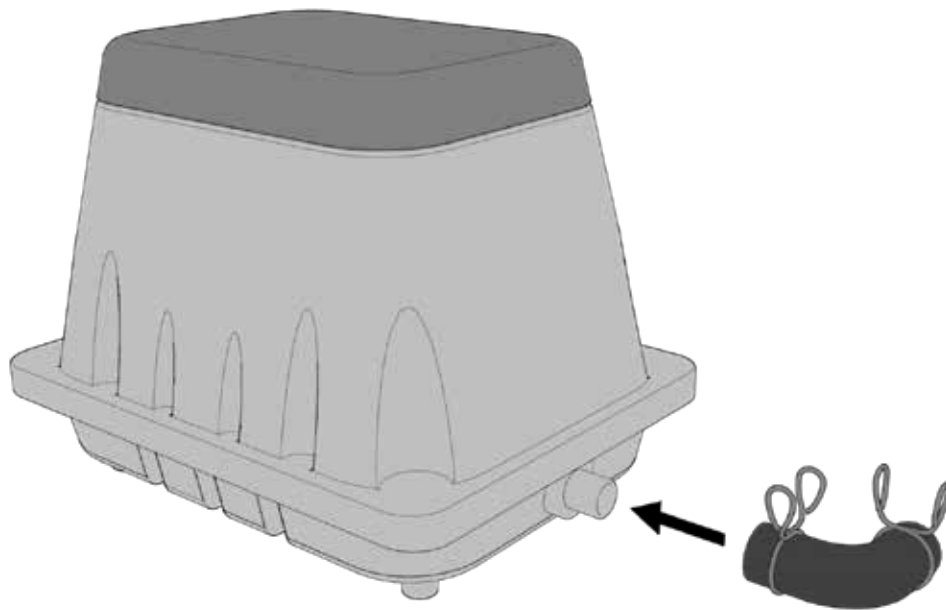

1. Unbox air pumps. Attach factory supplied 3/4" rubber elbow to outlet on each air pump.

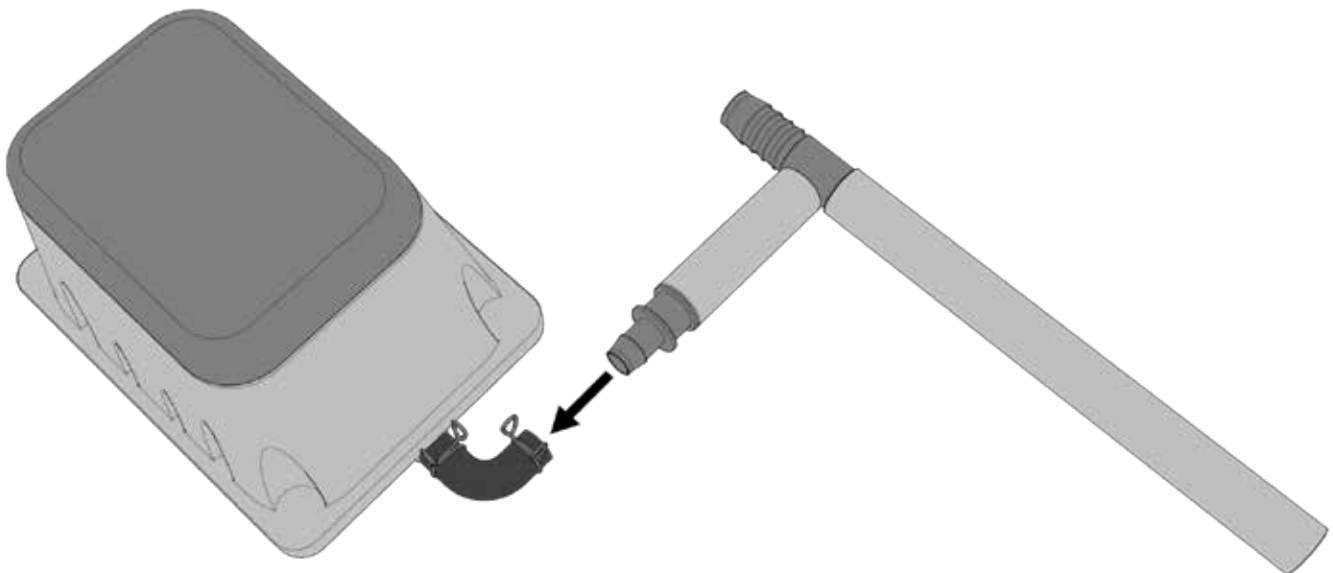

2. Attach (1) Air Pump Inlet Tee (APIT) to each air pump in the pump bank.



PHASE 3: AIR PUMP BANK

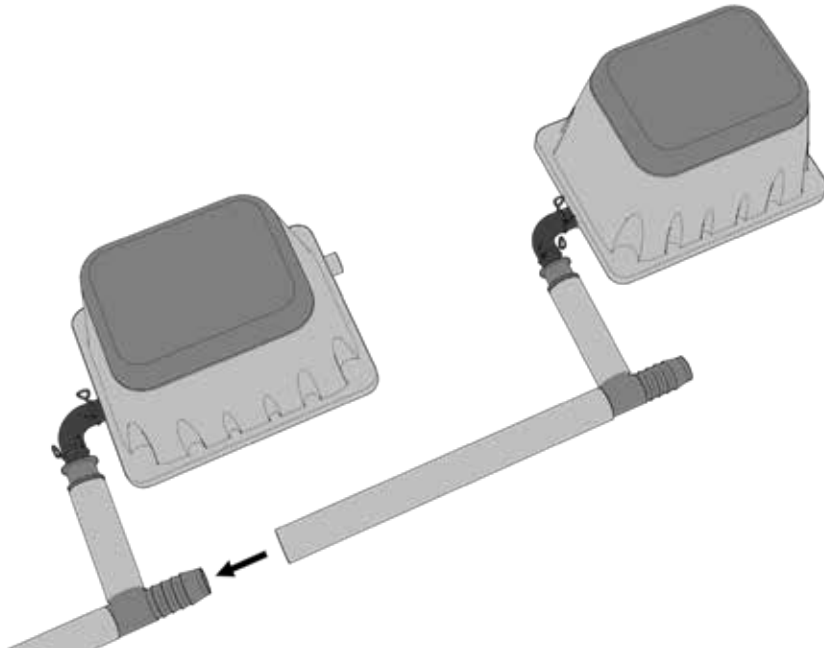

3. Adjoin each APIT in series. Connect outlet hose to the inlet barb on the following APIT.

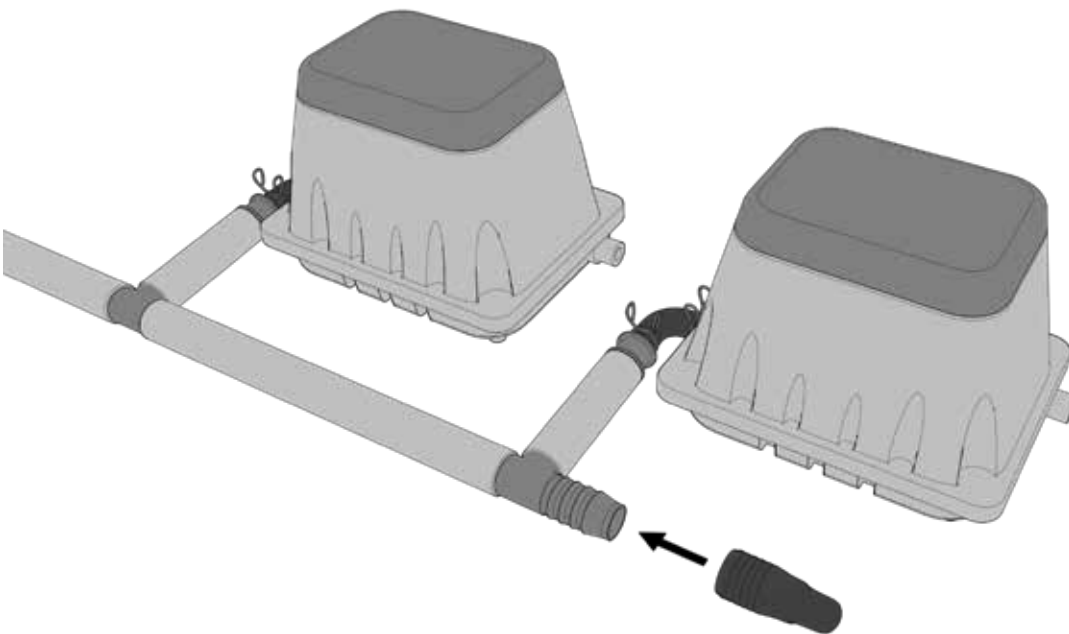

4. Attach 1" cap to open inlet barb on APIT.

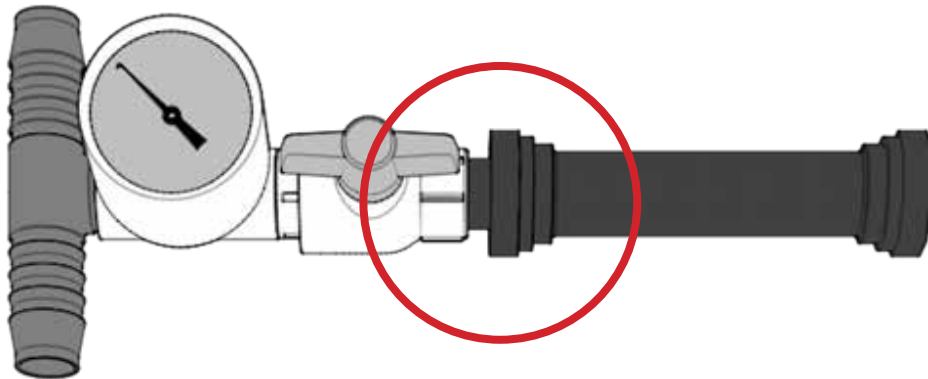

5. Unbox Air Flow Regulator (AFR). Attach Relief Outlet to Valve.

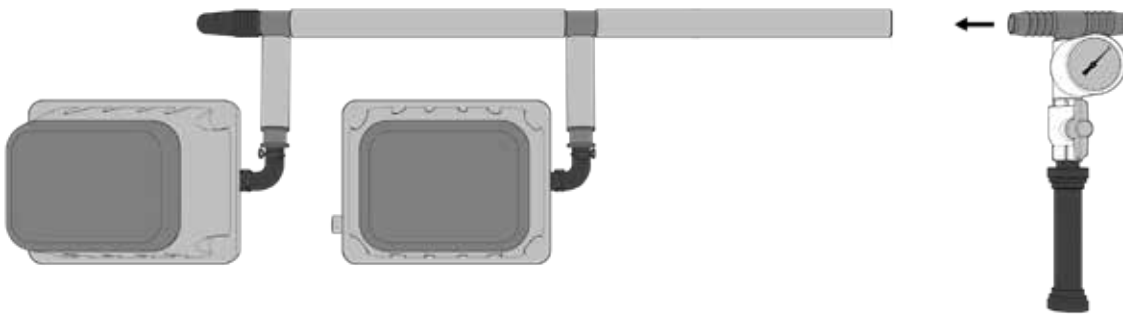

6. Connect outlet hose on first air pump in series to the inlet barb on the AFR.

7. Plug all Air Pumps into a heavy-duty surge protector (GFI Recommended).

Air Pump Bank with Air Flow Regulator is Complete!



PHASE 4: AERATION MANIFOLD

Move Aeration Manifold Joints, Aeration Blunts, Aeration Leads, Air Manifold Fittings and Air Stone Kits to Grow Area.

1. Layout all parts of the Aeration System in area adjacent to grow area. Group all Pipe in relative lengths.

2-Row

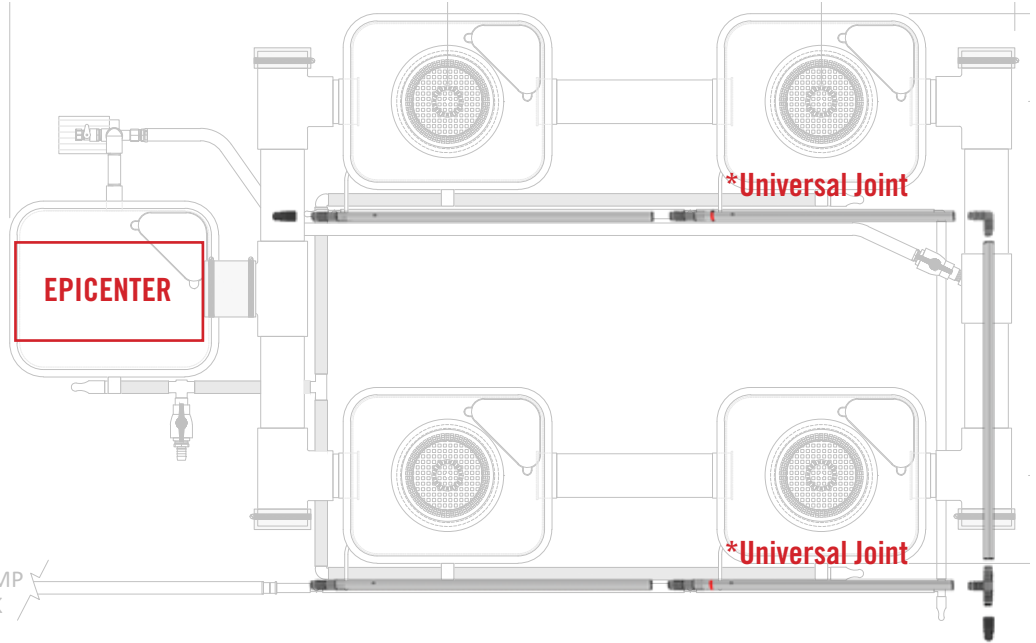

3-Row

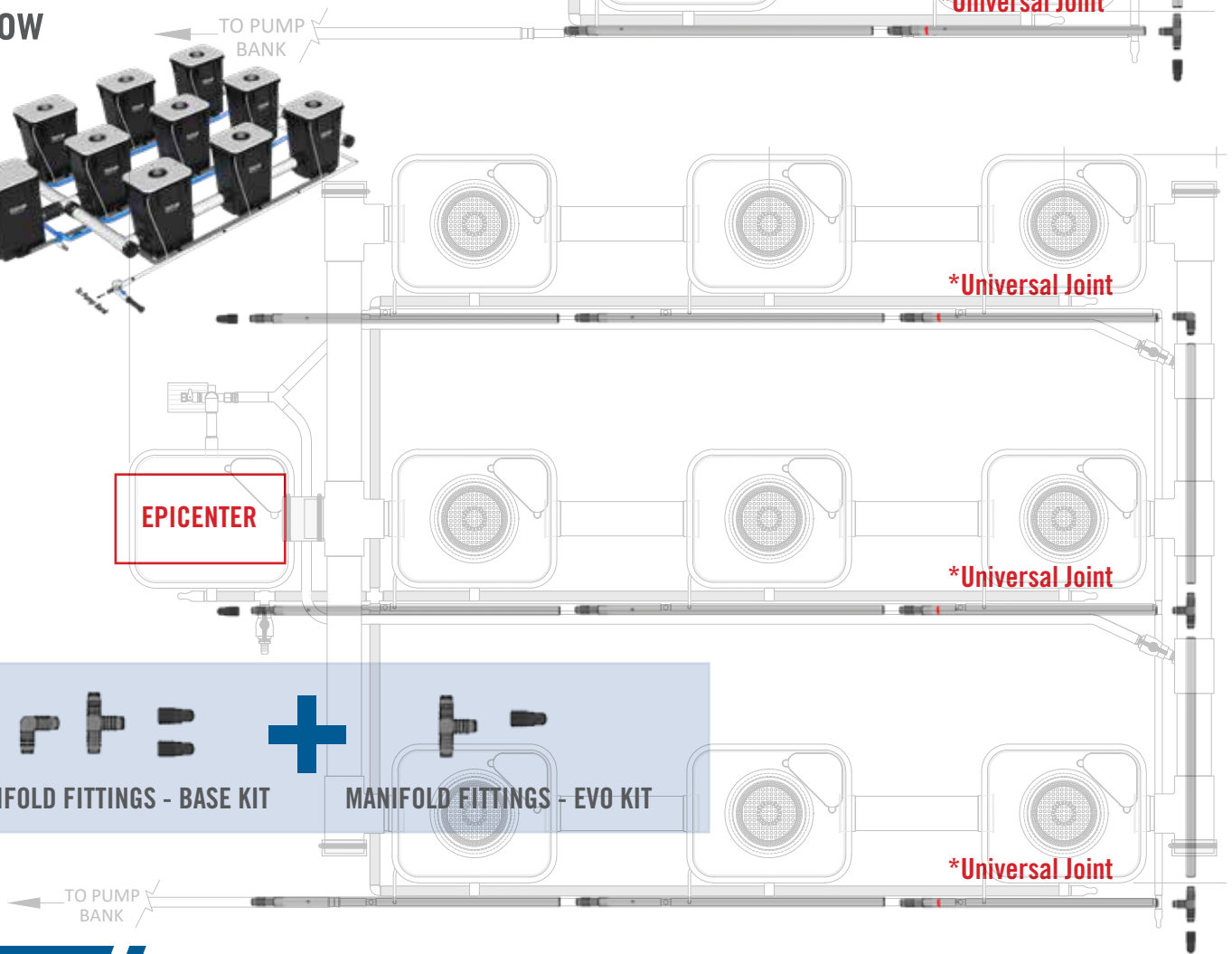
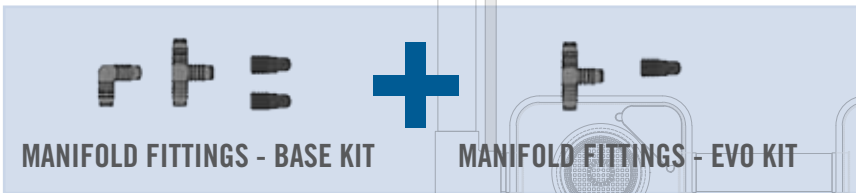

4-Row

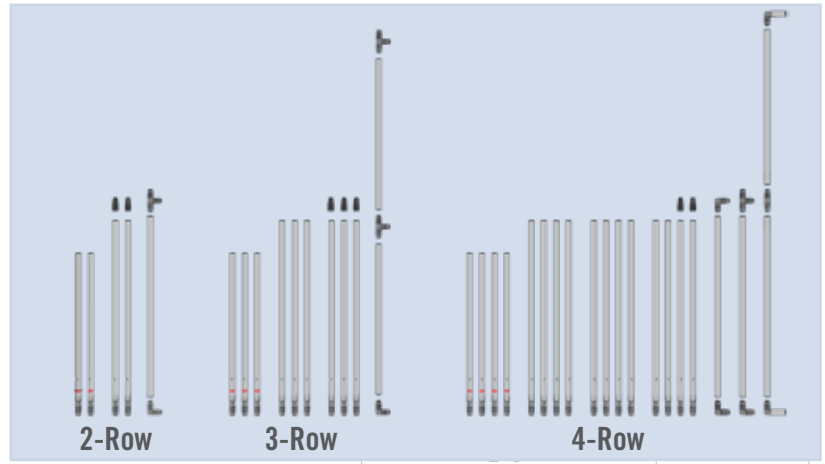

2-Row

3-Row

4-Row

EPICENTER



MANIFOLD FITTINGS - BASE KIT

MANIFOLD FITTINGS - DB KIT

*Universal Joint

*Universal Joint

*Universal Joint

*Universal Joint

PUMP BANK



PHASE 4: AERATION MANIFOLD

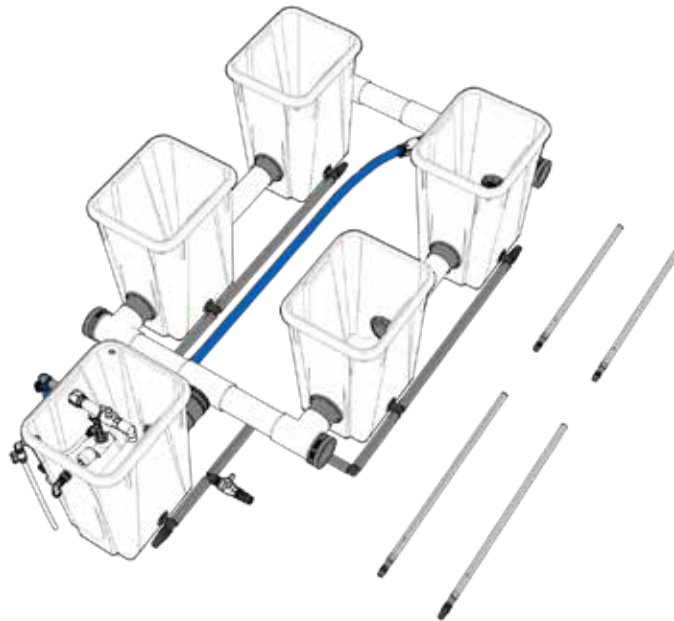

2. Lay out Aeration Joints alongside system, with barbed end facing Epicenter.
 - a. Layout a row of Aeration Joints for each corresponding row of the system being assembled. Example: Evolution has 3 rows, layout 3 rows of joints.
 - b. Begin each row of Aeration Joints with a UNIVERSAL JOINT (denoted with colored rubber band). The UNIVERSAL JOINT should be positioned nearest the Return Manifold.

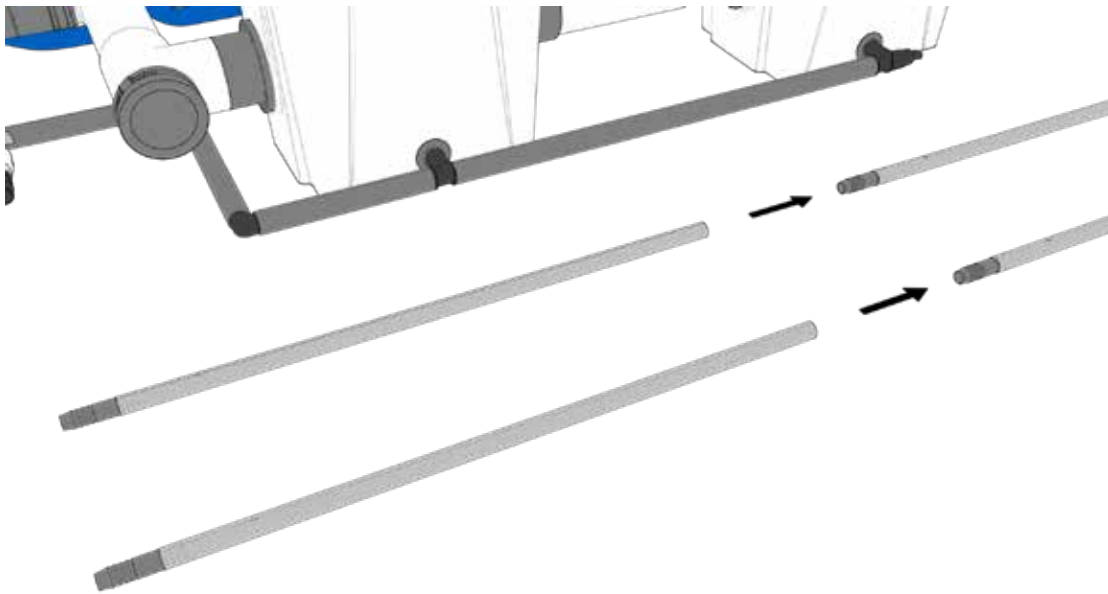

Be certain the print on the aeration pipe is aligned and facing down.

3. Attach all joints in series by pushing open end of aeration pipe onto the corresponding barb.

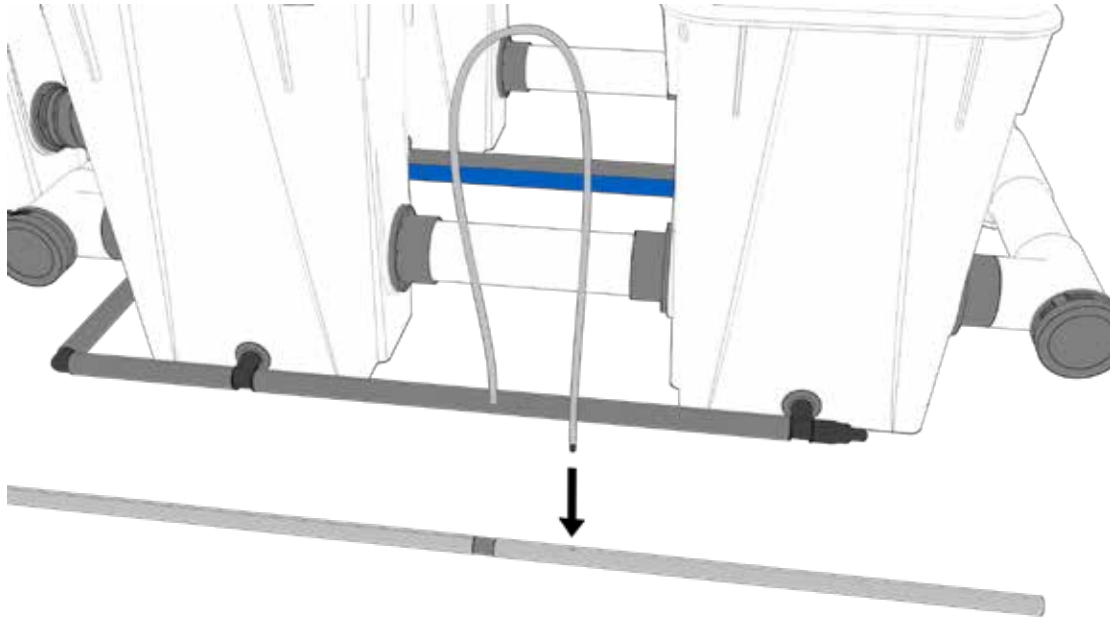

4. Install all Aeration Leads. Insert barded end of ¼" Aeration Lead into predrilled holes in the Aeration Joints. Make sure barb is fully seated in hole.

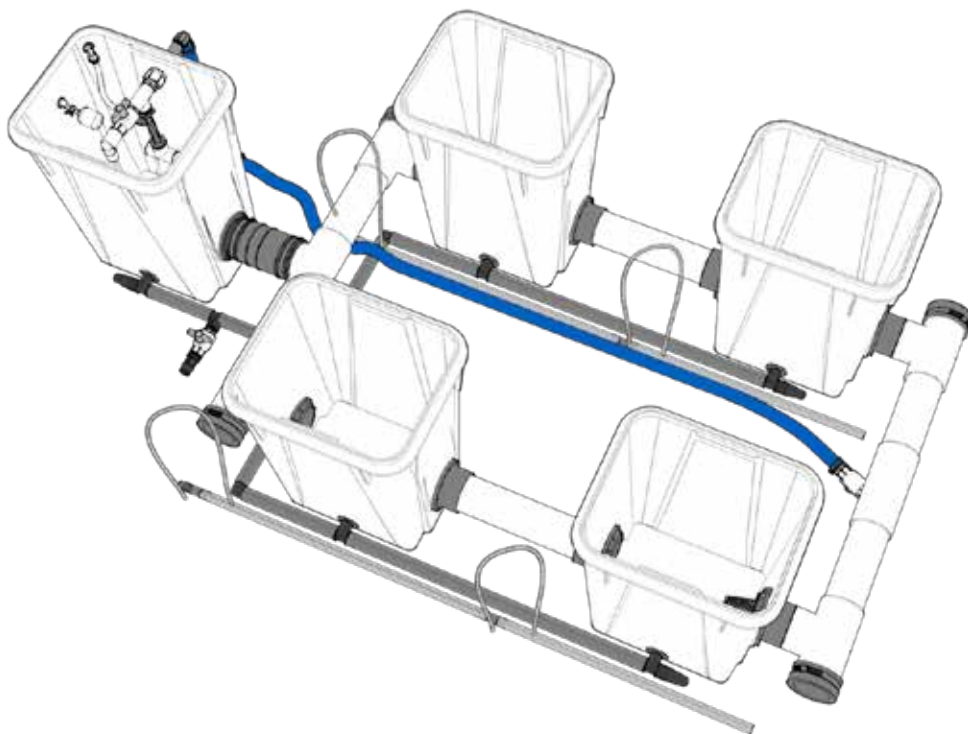

5. Move each row of connected Aeration joints alongside the corresponding row of Growth Modules. Aeration Joints should be placed on the Drain Well side of the row of Growth Modules.



PHASE 4: AERATION MANIFOLD

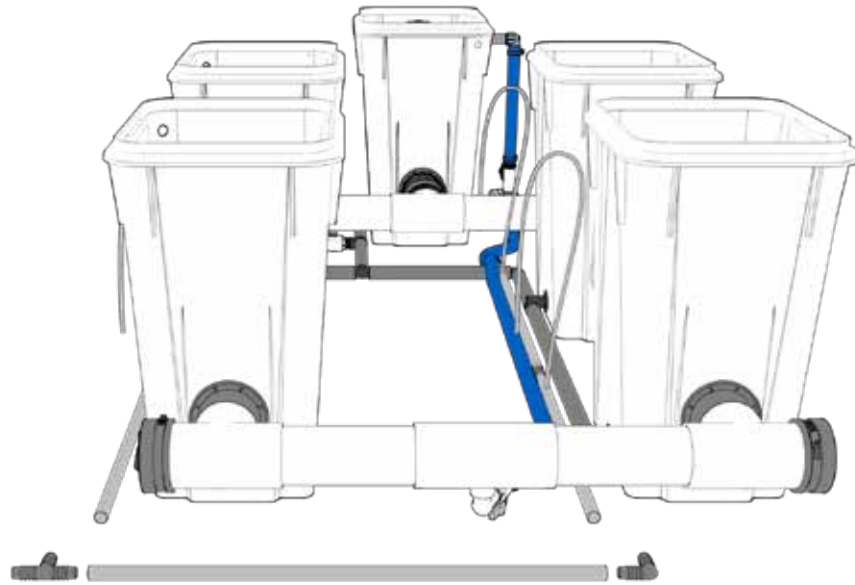

6. Layout Aeration Blunts, perpendicular to each row of Aeration Joints on the Return Manifold end of the system.

a. ****If assembling a Double Barrel (4 Row) System:** (2) designated Aeration Blunts will need to be connected with $\frac{3}{4}$ " barb and laid out on the Delivery Manifold side between the 2 most internally positioned rows. *SEE OVERVIEW ON PAGE 26.

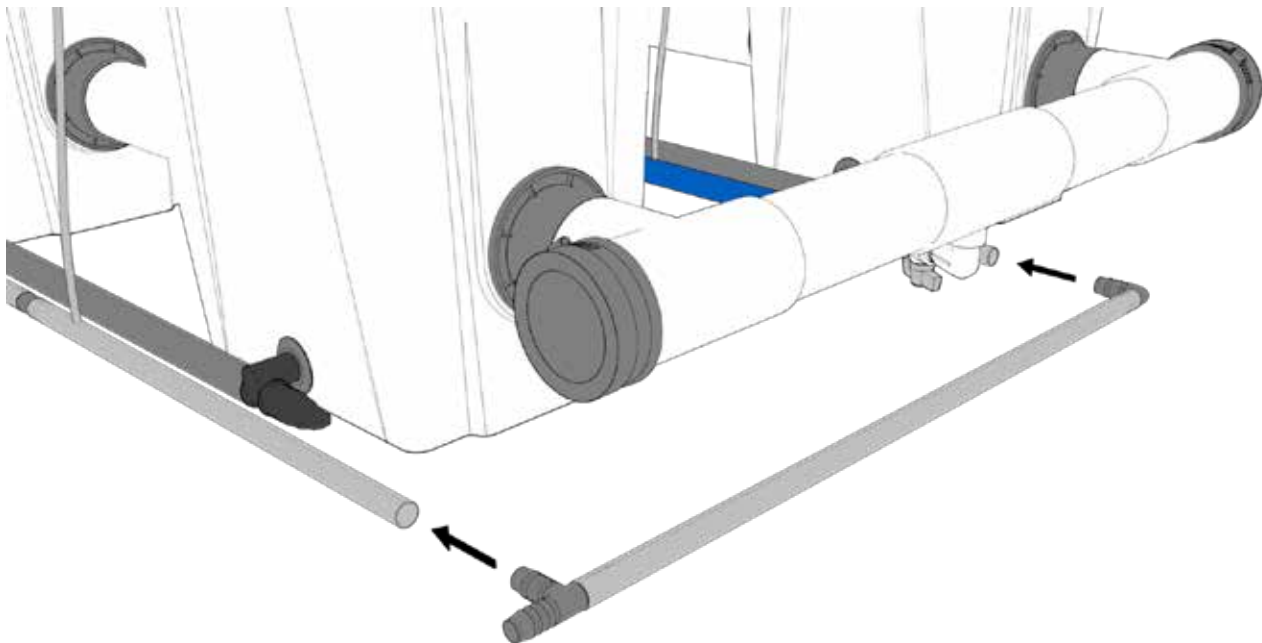

7. Using Aeration Fitting Kit ($\frac{3}{4}$ " tees/elbows), connect the Aeration Blunts to the corresponding Aeration Joints to create the completed Aeration Manifold.

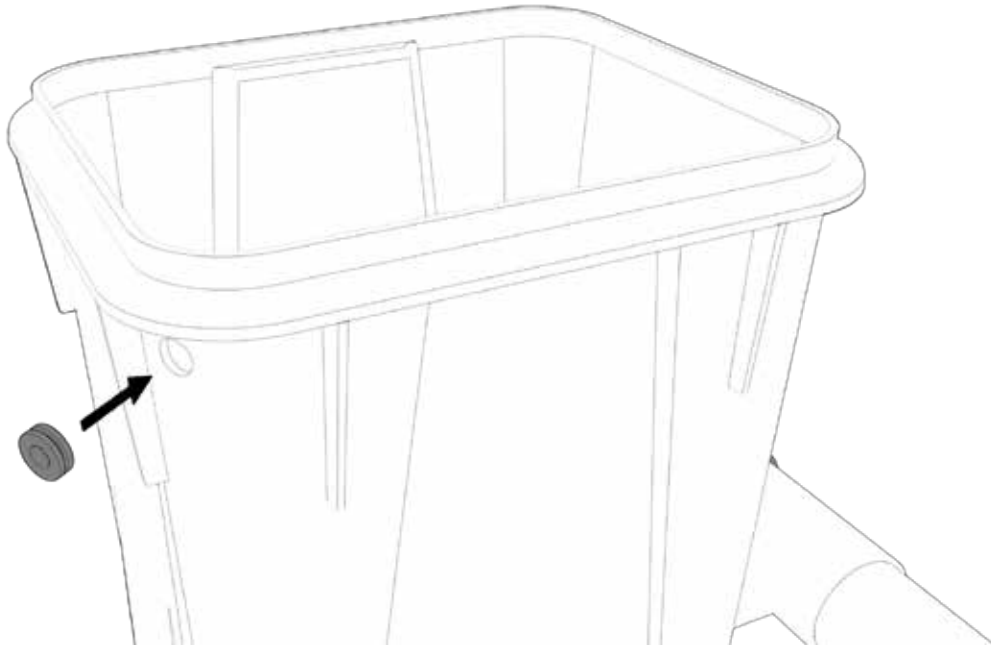

8. Insert grommets (Located in AIR STONE KIT) into air inlet hole near the upper lip of the GROWTH MODULE. Repeat for all GROWTH MODULES.



9. Create short horizontal leads. Connect $\frac{1}{4}$ " barbed elbow to 4" x $\frac{1}{4}$ " section of hose (Located AIR STONE KIT).



10. Remove AIR STONES (Located AIR STONE KIT) from packaging. Connect short horizontal lead to Air Stone to create Air Stone Assembly, place in base of GROWTH MODULE.



PHASE 4: AERATION MANIFOLD

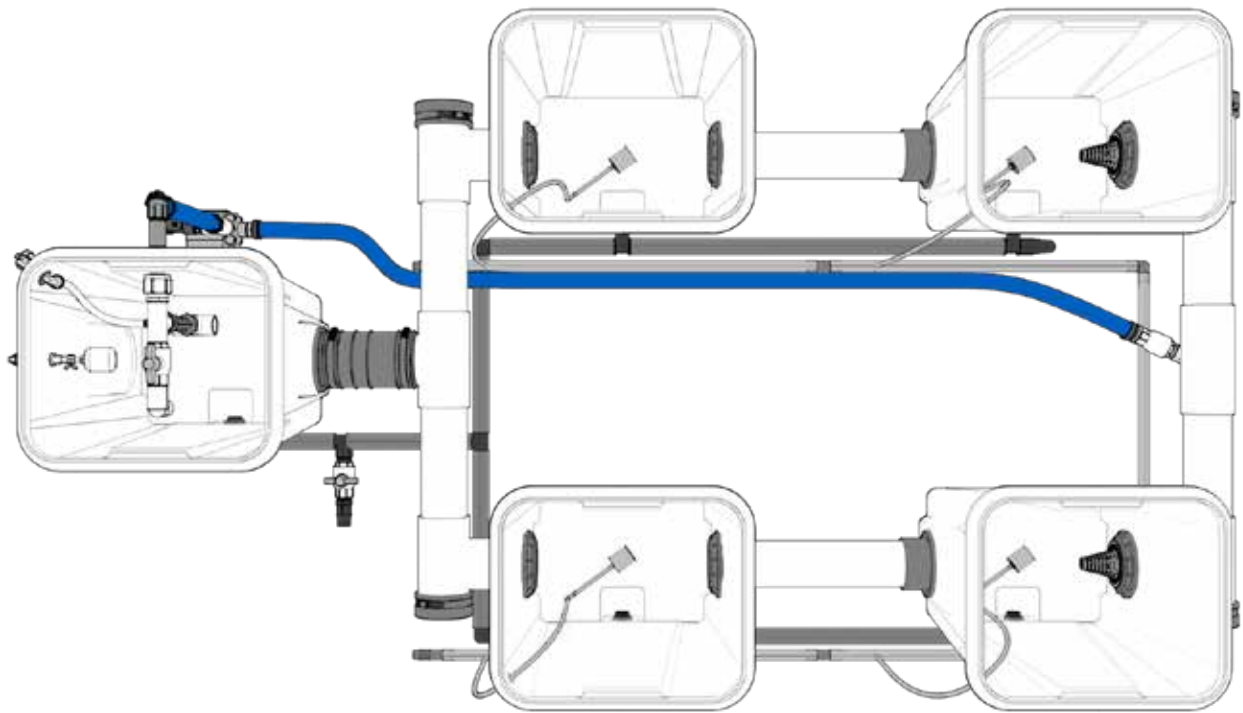

11. Push Aeration Lead (attached to Aeration Manifold) through the side entry hole in GROWTH MODULE. Connect to Air Stone Assembly and position in center of GROWTH MODULE with air stone lying on it's side.

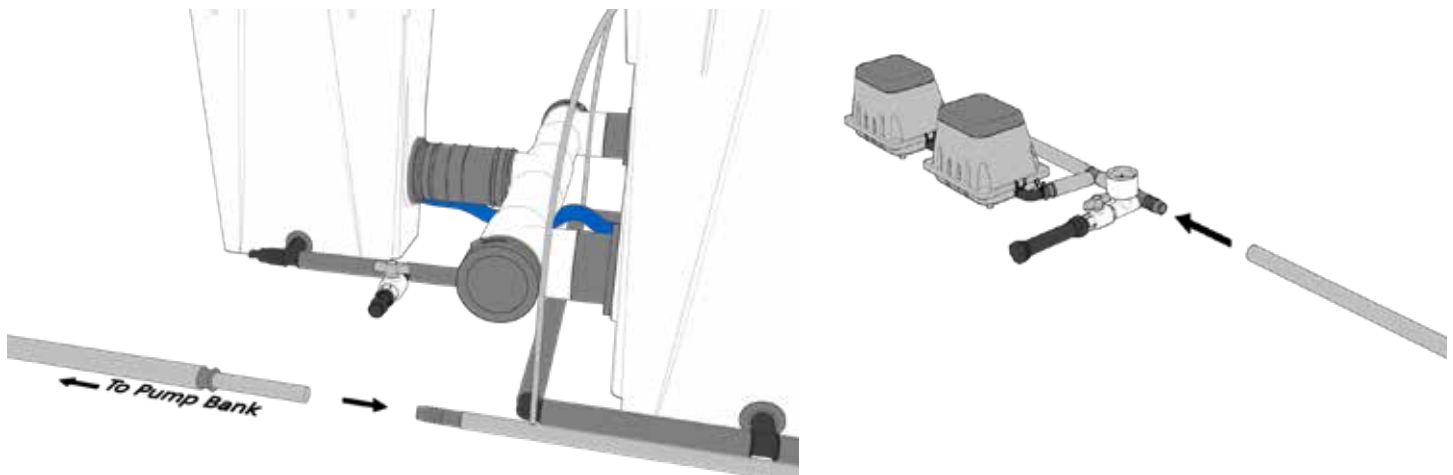

12. Connect Aeration Manifold to Air Pump Bank with Air Flow Regulator.
- Connect $\frac{3}{4}$ " section of Air Supply Hose to any open $\frac{3}{4}$ " barb on the Aeration Manifold. Choose the inlet location nearest the Air Pump Bank with Air Flow Regulator.
 - Attach opposite end of 1" Air Supply Hose to the outlet barb on the Air Flow Regulator.

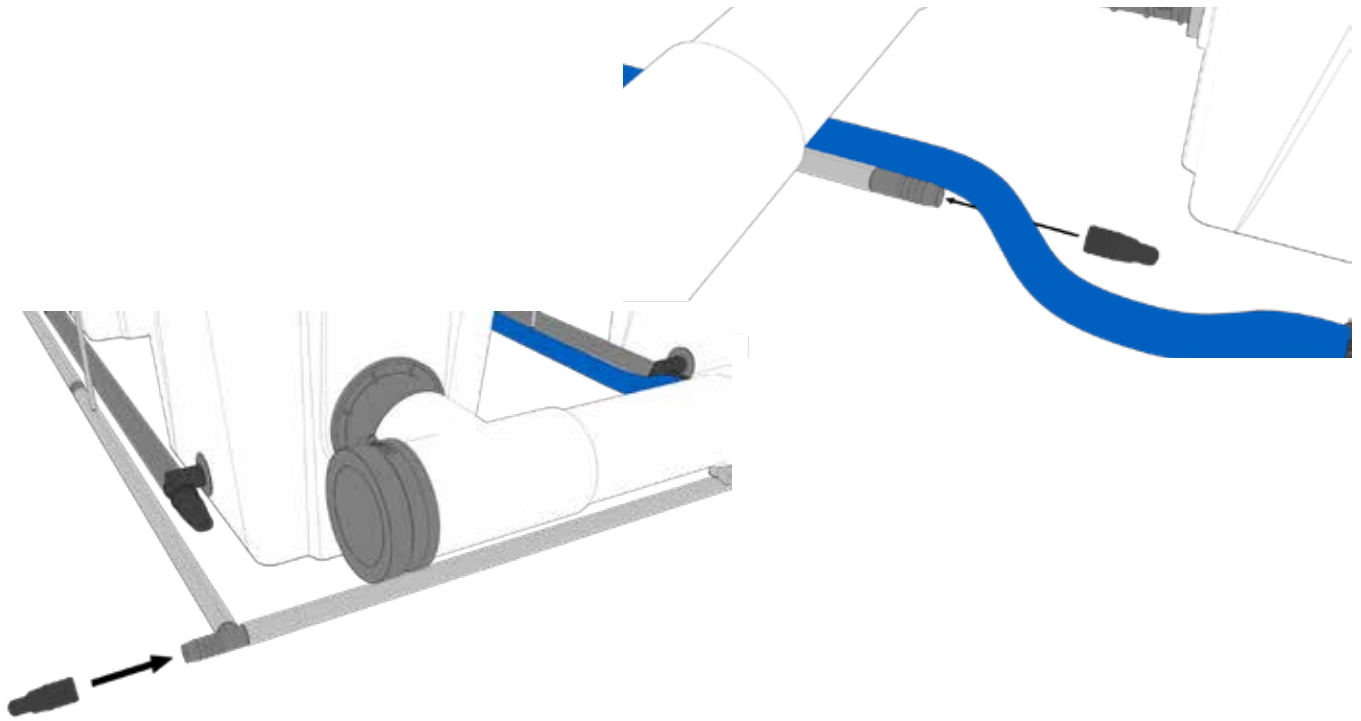

13. Apply 3/4" caps to any open barbs throughout the Aeration Manifold.

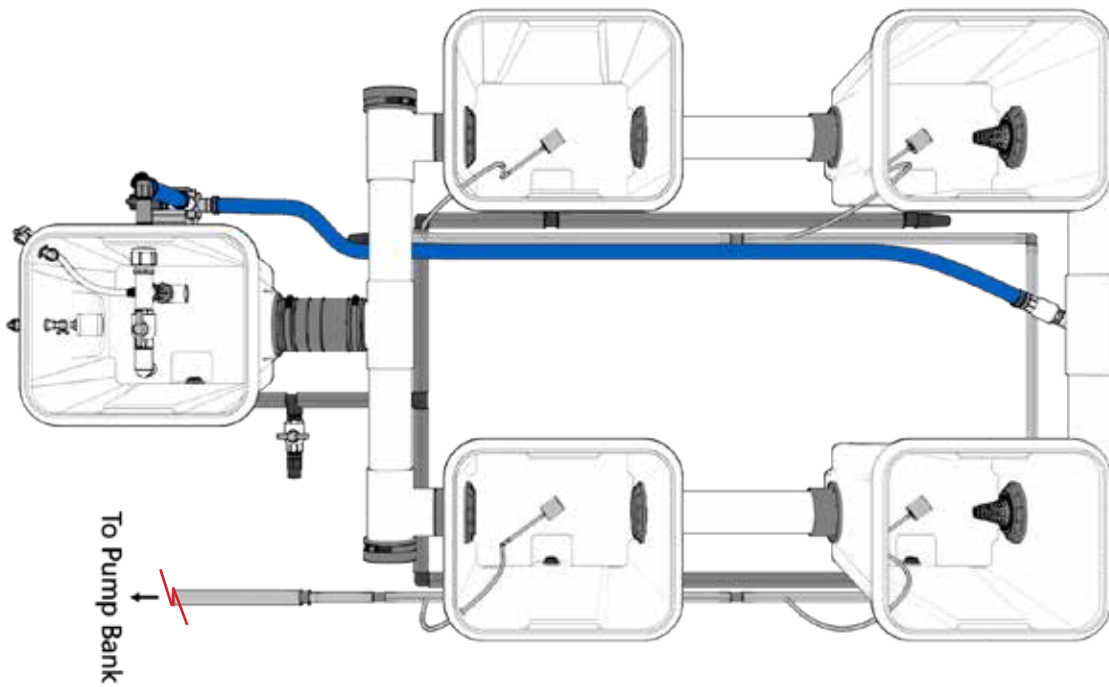

Aeration Manifold is Complete!

System Assembly is Complete!



PHASE 5: SYSTEM INITIATION

1. Aeration System Startup & Priming

- a. Before adding water to system, power up pump bank and initiate aeration. Beginning aeration before submersing air stones aides in priming the aeration system for optimal output.
- b. ***Aeration System output is measured using the metric of “inches water column” (IWC). This measurement provides a useful standard for establishing output baselines for operating your UC system.
- c. With AFR bleed valve in the fully closed position, Initiate power to the air pump bank
- d. Run without water.

2. Test Fill & Leak Check

- a. Begin filling system with water.
- b. Once system has reached desired capacity, observe reading on gauge
- c. ***Test fill system to just above BULKHEADS, check for leaks. Run return pump for 1 hour, re-check often for leaks. Adjust and tighten BULKHEADS as necessary. If a leak is discovered and you're unable to fix, call CCH2O @ 559-266-4769 for support.

3. Aeration Calibration

- a. Target gauge reading for the Air Flow Regulator is 20-25 IWC
- b. To calibrate the IWC to the target setting, slowly open bleed valve and observe IWC begin to fall
- c. Once needle on gauge reads 20-25, simply leave bleed valve in this set position
- d. Pump bank and aeration system is calibrated and ready for operation
- e. ***Do not turn off air pumps while air stones are submersed. Doing so can result in a siphon action that will pull nutrient solution and debris into air stones rendering them less effective. Always remove air stones from the nutrient solution before disengaging pump.

PHASE 6: PLANTING

1. Install LIDS

- Install Lids to each GROWTH MODULE, install PORT HOLE COVER(S) on each LID.
- Install EPICENTER LID on EPICENTER.

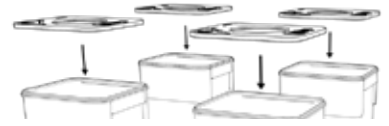

2. Add Nutrients

- Add desired nutrient through Add Back Kit.
 - Adjust your nutrient strength to week 1 of Veg on the Cultured Solutions Feeding Schedule.

3. pH Balancing (Without Plants in System)

- Add desired pH adjuster through Add Back Kit.
 - Fill a container with 10-parts water, add 1-part Add Back concentrate. (Example: 1000mL water with 100mL concentrate)
 - Insert clear hose into container with diluted concentrate and open 3/8" valve.
 - Close 3/4" valve to initiate Add Back flow. See Figure 1.
 - Valve position may be adjusted to speed/slow flow. See Figure 2.
 - Once Add Back is complete, open 3/4" valve to resume normal system circulation. See Figure 3.
- Allow solution pH to stabilize (Approx 15-30 mins).
- Once solution is balanced, introduce plants.



4. Introducing Plants into the Under Current

- Rinse grow rocks/stones thoroughly before use.
- Rest bare root seedling/cutting on planting deck, drape exposed roots over planting deck towards the bottom of the NET POT.
- Gently fill around the seedling/cutting roots up to about 1" from the top lip of NET POT.
- Place NET POT into the LID on top of each GROWTH MODULE.



BARE ROOT

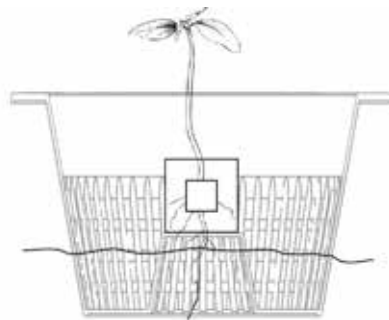

ROCKWOOL



RESERVOIR INSTALLATION

CCH2O TIP:

A top-off reservoir is used to maintain consistent system volume. The top-off reservoir also helps to keep water chemistry stable. Fluctuations in pH and EC can have a negative effect on plant health.

The Top-off reservoir will supply solution via gravity to the float valve in the Epicenter (control module). When operated properly, the top-off reservoir should be balanced to be the same or slightly higher as the nutrient solution in the system.

Reservoir Installation

1. Attach a top-off reservoir to the FLOAT VALVE using the RESERVOIR ADAPTER KIT.
 - a. Drill 1-1/4" hole near base of desired reservoir, install UNISEAL and RESERVOIR ADAPTER. Connect RESERVOIR ADAPTER to FLOAT VALVE QUICK CONNECT ELBOW with RESERVOIR HOSE.
 - b. Reservoir should be elevated above EPICENTER.
 - c. RESERVOIR HOSE can be lengthened to place reservoir further away from EPICENTER.

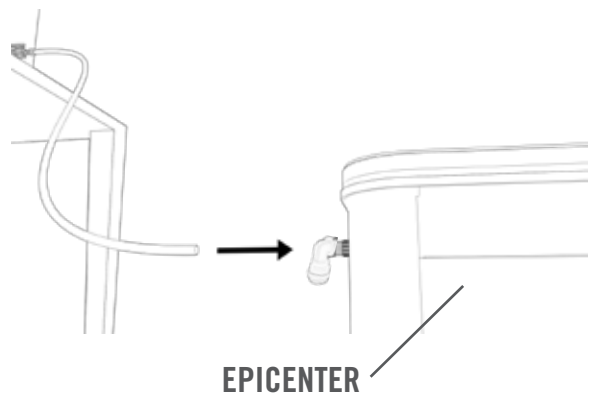
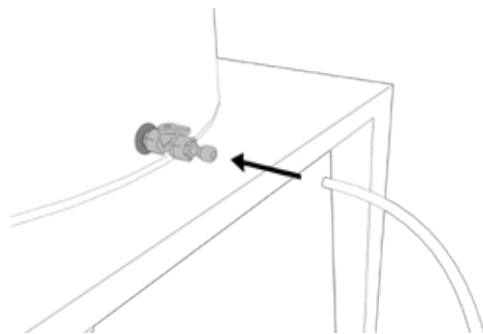
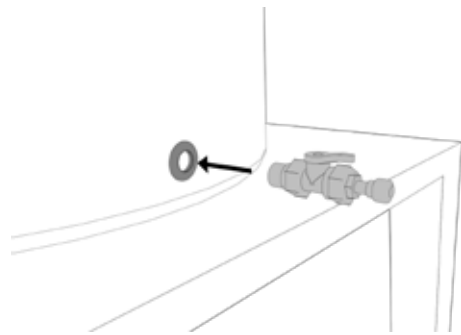
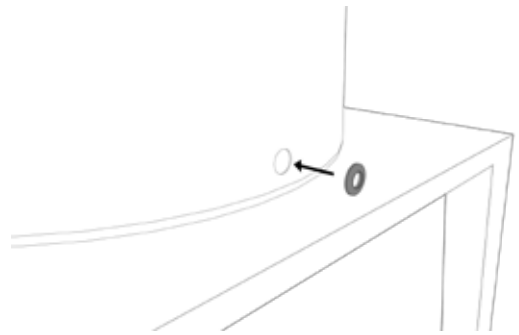

CHILLER INSTALLATION

Water Chiller Installation

The Under Current® can easily be adapted to a water chiller in one of the following ways:

1. Remove the upright hose section of the PUMP KIT, attach 1" hose (not included) from the output barb on the RETURN PUMP to the chiller inlet. Attach 1" hose (not included) from the chiller outlet back to the 1" barb on the EPI STEM.
2. For cooling multiple Under Current® systems with one large chiller you can use the Cool Coil® from Surna (www.surna.com). One Cool Coil® is needed for each system/EPICENTER.

Contact Surna for more information.



DRAINING & CLEANING

Draining the System without the DRAIN OUT KIT

Draining the system can be done in two ways:

1. Attach a GARDEN HOSE to the bypass valve on the RETURN PUMP outlet. Close ADD BACK KIT valve to initiate flow. Monitor water level as system drains to not let RETURN PUMP run dry.
 - a. This will drain system to within 1". Top off system with fresh water while draining to dilute remaining solution.
2. Turn OFF system's circulation pump. Remove cap from DRAIN VALVE. Attach female side of garden hose to DRAIN VALVE. Run garden hose to desired location (Preferably a lower elevation than the DRAIN VALVE). Open DRAIN VALVE.
 - a. This will drain system to within 1". Top off system with fresh water while draining to dilute remaining solution.
3. To drain the system completely use our optional Drain Out Kit or a wet/dry vacuum in each module.

Draining the System with the DRAIN OUT KIT

The DRAIN OUT KIT can be used with or without a TRANSFER PUMP:

1. Without Pump: Turn OFF system's circulation pump. Attach a GARDEN HOSE to the DRAIN OUT KIT VALVE. Run garden hose to desired location (Preferably a lower elevation than the VALVE). Open DRAIN OUT KIT VALVE.
2. With TRANSFER PUMP: Attach TRANSFER PUMP to the DRAIN OUT KIT VALVE. Attach GARDEN HOSE to TRANSFER PUMP. Run TRANSFER PUMP hose to desired location. Open DRAIN OUT KIT VALVE. Turn on TRANSFER PUMP. Monitor water level as system drains to not let TRANSFER PUMP run dry.

Cleaning the System (Without Plants in System)

1. Pull out root mass and discard AIR STONES.
2. Drain the system completely. Remove any remaining water and debris with a wet/dry vacuum.
3. Wipe down air hose, net pots and lids with sterilizing solution on a green pad or wash cloth.
4. Fill the system with tap water and sterilizing solution to the top of the buckets, run for minimum 4-6 hrs.
5. Scrub inside of modules with green pad and inside joints with bottle brush.
6. Rinse out the system with a hose while draining till drain water is clear.
7. Drain remaining solution down as far down as possible.
8. Remove remaining water with wet/dry vacuum or sump pump.
9. Wipe dry with a towel.
10. Let dry fully under HID lights to aid in sterilizing.

MAINTENANCE & DISPOSAL

Replacement Items

Replacement parts are available through all CCH2O Authorized Dealers. These items are not covered under our Limited 3-year Warranty and should be replaced regularly to maintain system performance and cleanliness. Most items can be cleaned and re-used with each successful run. If any items become damaged or you are unable to clean them sufficiently they should be replaced.

- **Net Pots** – Net pots should be replaced as needed. Net pots can be cleaned and re-used in most cases. If net pots become damaged or are unable to properly support plants they should be replaced.
- **Air Stones** – Air Stones should be replaced with each full run. Air Stones can clog or harbor bacteria and pathogens if not cleaned properly between runs. Replacing the Air Stones will allow for maximum aeration with the least back pressure.
- **Air Hose Leads** – Air hose leads should be replaced as needed. Replace air hose leads if lines become kinked or damaged and air levels start diminish.
- **Return Hose** - Return hose should be replaced as needed. Return hose can harbor bacteria and pathogens if not cleaned properly between runs. Replace return hose if lines become kinked or damaged and flow levels start to diminish.



System Disposal & Recyclable Items

Each component of the Under Current system has been chosen for longevity and durability in adverse growing environments. Though we offer a Limited 3-year Warranty, most of your systems components have been optimized for a much longer life. In our pursuit of a fully recyclable system we've worked hard to source parts that are made from re-usable plastics. In the event you plan on disposing of your systems components please use the following information to do so responsibly:

- **Modules** – Made from food grade Polypropylene. Can be recycled.
- **Lids, Net Pots, Bulkheads** – Made from Recycled ABS. Can be recycled.
- **Joints** - Made from virgin ABS. Can be recycled.
- **Manifolds** – Bulkheads and straight pipe are ABS and can be recycled. Elbows and tees are PVC and can be recycled but only through specialty recycler.
- **Air Hose/Aeration Manifold** - Made from EVA. Can be recycled.
- **Return Hose** - Made from FPVC. Can be recycled but only through specialty recycler.



BULKHEAD INSTALLATION

*FOR BONELESS APPLICATIONS

UC Spin-Tight Bulkhead - Assembly and Installation Recommendations

Thank you for purchasing our UC Spin Tight Bulkheads. To ensure your bulkheads function properly, follow the instructions below for installation. In the event you have a question, please contact CCH2O Tech Support @ 559-266-4769 ex.2 to leave a message or email us at tech@cch2o.com

*****NOTE: Take extra precautions and educate yourself when working with the tools and supplies necessary to bond and plumb plastic and bulkheads correctly. Consult with an online plumbing tutorial if further insight is necessary on the specifics of cutting and fitting pipe.**

DRILLING

Be certain to take great care in drilling your holes! An improperly drilled hole will result in a poor seal and leakage. When drilling holes in containers to accept UC Spin Tight Bulkheads, we recommended drilling the following sizes:

2" Bulkhead = 2-7/8" Hole

3" Bulkhead = 3-7/8" Hole

GLUING

UC Spin Tight Bulkheads are made of ABS plastic and designed with one male threaded connection (which enters hole in module) and one socket side which is designed to accept 2" or 3" schedule 40 PVC. To make this pipe to bulkhead connection, we recommend the appropriate glue be used relative to the pipe material being installed.

ABS to PVC: If connecting to PVC use glue suitable for bonding ABS to PVC. We recommend WELD ON ABS/PVC GLUE 794.

ABS to ABS: If connecting to ABS use glue suitable for bonding ABS to ABS. We recommend WELD ON ABS GLUE 773.

If these glues are not available, use whatever comparable substitute you can source.

INSTALLATION

Factors such as hole distortion, un-level floors and inattention to detail can all play a roll bulkheads not functioning properly. For best results be cautious, take your time and use care when installing UC Spin Tight Bulkheads. Always consult a professional if necessary.

*****NOTE: Do NOT use and lubricants or adhesives on the UC Spin Tight Bulkhead during the installation process.**

- 1) Press flat gasket down to fully seat and install on flat flange on the outside of the bulkhead body. Be certain the gasket is fitted onto the flange as improper fitting will lead to leaks.
- 2) Insert male threaded side of bulkhead through the hole in your container and press the fitted gasket firmly against the side wall of container. Visually inspect for gaps.
- 3) Place Bulkhead Nut on male threads and hand tighten.
- 4) Once all bulkheads are installed using steps 1-3, follow up by tightening nuts with supplied bulkhead wrench until firmly secured. Do not over tighten as this may lead to leakage.
- 5) Once properly installed you can now begin to fill your containers with fluid to check for leaks. For initial inspection, we recommend filling to just above the top of bulkhead and let stand for a half hour before continuing inspection. If a leak is discovered, you can use the bulkhead wrench to tighten further.
- 6) If additional tightening does not remedy seal it may be necessary to repeat steps 1-4 again to reseat bulkhead properly. If issues persist, please contact CCH2O Tech Department for more assistance.

BONELESS CUT CHART

Boneless PVC Sizing Chart

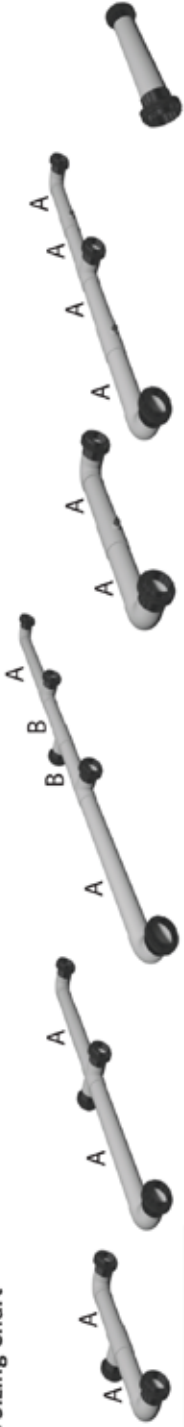

SYSTEM SIZE: 8 GALLON

QTY. NEEDED	STANDARD - 2 ROW		DELIVERY MANIFOLD		DOUBLE BARREL - 4 ROW		RETURN MANIFOLD		JOINT
	2	A	EVOLUTION - 3 ROW	2	2	2	STANDARD - 2 ROW	EVOLUTION - 3 ROW	
PLANT CENTERS	18"	7.25"	17"	17"	17"	7.25"	A	A	3"
	25"	9.25"	21.5"	21.5"	21.5"	9.25"	A	8"	10"
	30"	11.75"	26.5"	26.5"	26.5"	11.75"	A	10"	15"
	35"	14.25"	31.5"	31.5"	31.5"	14.25"	A	15"	20"

SYSTEM SIZE: 13 GALLON

QTY. NEEDED	STANDARD - 2 ROW		DELIVERY MANIFOLD		DOUBLE BARREL - 4 ROW		RETURN MANIFOLD		JOINT
	2	A	EVOLUTION - 3 ROW	2	2	2	STANDARD - 2 ROW	EVOLUTION - 3 ROW	
PLANT CENTERS	30"	10.75"	25.5"	25.5"	25.5"	10.75"	A	A	14.5"
	35"	13.25"	31"	31"	31"	13.25"	A	12"	19.5"
	40"	16"	36"	36"	36"	16"	A	14.5"	24.5"
	45"	18.5"	41"	41"	41"	18.5"	A	17.25"	29.5"
	50"	20"	46"	46"	46"	20"	A	19.75"	34.5"
	55"	22.5"	51"	51"	51"	22.5"	A	22.25"	39.5"
	60"	25"	56"	56"	56"	25"	A	24.75"	44.5"
	65"	27.5"	61"	61"	61"	27.5"	A	27.25"	49.5"

SYSTEM SIZE: 35 GALLON

QTY. NEEDED	STANDARD - 2 ROW		DELIVERY MANIFOLD		DOUBLE BARREL - 4 ROW		RETURN MANIFOLD		JOINT
	2	A	EVOLUTION - 3 ROW	2	2	2	STANDARD - 2 ROW	EVOLUTION - 3 ROW	
PLANT CENTERS	40"	16"	36"	36"	36"	16"	A	A	9.5"
	45"	18.5"	41"	41"	41"	18.5"	A	17.25"	14.5"
	50"	21"	46"	46"	46"	21"	A	19.75"	19.5"
	55"	23.5"	51"	51"	51"	23.5"	A	22.25"	24.5"
	60"	26"	56"	56"	56"	26"	A	24.75"	29.5"
	65"	28.5"	61"	61"	61"	28.5"	A	27.25"	34.5"
	70"	31"	66"	66"	66"	31"	A	29.75"	39.5"
	75"	33.5"	71"	71"	71"	33.5"	A	32.25"	44.5"
	80"	36"	76"	76"	76"	36"	A	34.75"	49.5"

***All PVC cut lengths assume one plant per module. Dimensions are as accurate as possible and may be off 0.5" +/-.



CS FEEDING SCHEDULE

RE-CIRCULATING HYDRO

Under Current®, DWC/RDWC, Aeroponics, NFT

More Info @ cch2o.com



USE WITH:

- Under Current®
- DWC/RDWC
- Aeroponics
- NFT (Nutrient Film Technique)

** For Under Current® PRO or systems with hyper-aeration (>1.25 lpm/gal), nutrient levels must be reduced even further. **CUT ALL VALUES IN HALF.** Less is more!

ML PER GALLON	VEG				BLOOM								FLUSH	
	1	2	3	4	1	2	3	4	5	6	7	8		2-3DAY
UC ROOTS	2-5	2-5	2-5	2-5	2-5	2-5	2-5	2-5	2-5	2-5	2-5	2-5	2-5	5-10
COCO CAL	1-2	1-2	1-2	1-2	1.5-3	1.5-3	1.5-3	1.5-3	1.5-3	1.5-3	1.5-3	1.5-3	1-2	
VEG A	0.5	1	2	2.5										
VEG B	0.5	1	2	2.5										
BLOOM A					3.5	4.5	6	6	7.5	6	4.5	3		
BLOOM B					3.5	4.5	6	6	7.5	6	4.5	3		
BUD BOOSTER- EARLY					0.5	1.5	1.5							
BUD BOOSTER- MID								3	1.5	1.5	1.5	1		
BUD BOOSTER- LATE													1/8TSP.	1/8TSP.
PPM (500 SCALE)	100	175	300	325	425	500	600	650	700	600	450	400	0-100	
PPM (700 SCALE)	140	245	420	455	595	700	840	910	980	840	630	560	0-100	
EC	0.2	0.35	0.6	0.65	0.85	1	1.2	1.3	1.4	1.2	0.9	0.8	0-0.1	
TARGET PH	6.3	6.2	6.1	6	6	6	5.9	5.9	5.9	5.8	5.8	5.8	5.8	
SOLUTION TEMP	72	70	70	68	68	68	68	68	68	68	66	64	64	

FOR ALL HYDRO APPLICATIONS



CULTURED SOLUTIONS®
PREMIUM HYDROPONIC NUTRIENTS

GENERAL USAGE INSTRUCTIONS

- Amounts are measured in milliliters per gallon of water.
- Dilute nutrients before mixing with other formulas, DO NOT MIX CONCENTRATES.
- Clean measuring cup thoroughly between nutrients.
- Use nutrient solution immediately after mixing or keep nutrient solution circulated.

STARTING WATER

Recommended source water PPM 0-20. Use reverse osmosis filtered water for best results. When using reverse osmosis water add Cultured Solutions® COCO CAL to the nutrient solution at recommended dosage.

PH LEVELS

Recommended source water pH 6.5 - 7. Optimal solution pH range after nutrients are added is 5.5 - 6.5. Adjust as necessary to achieve desired range.



Feeding Schedules
Nutrient Calculator



General Recommendations
App Coming Soon!

GENERAL RECOMMENDATIONS

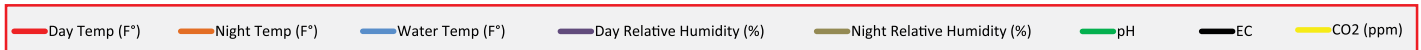
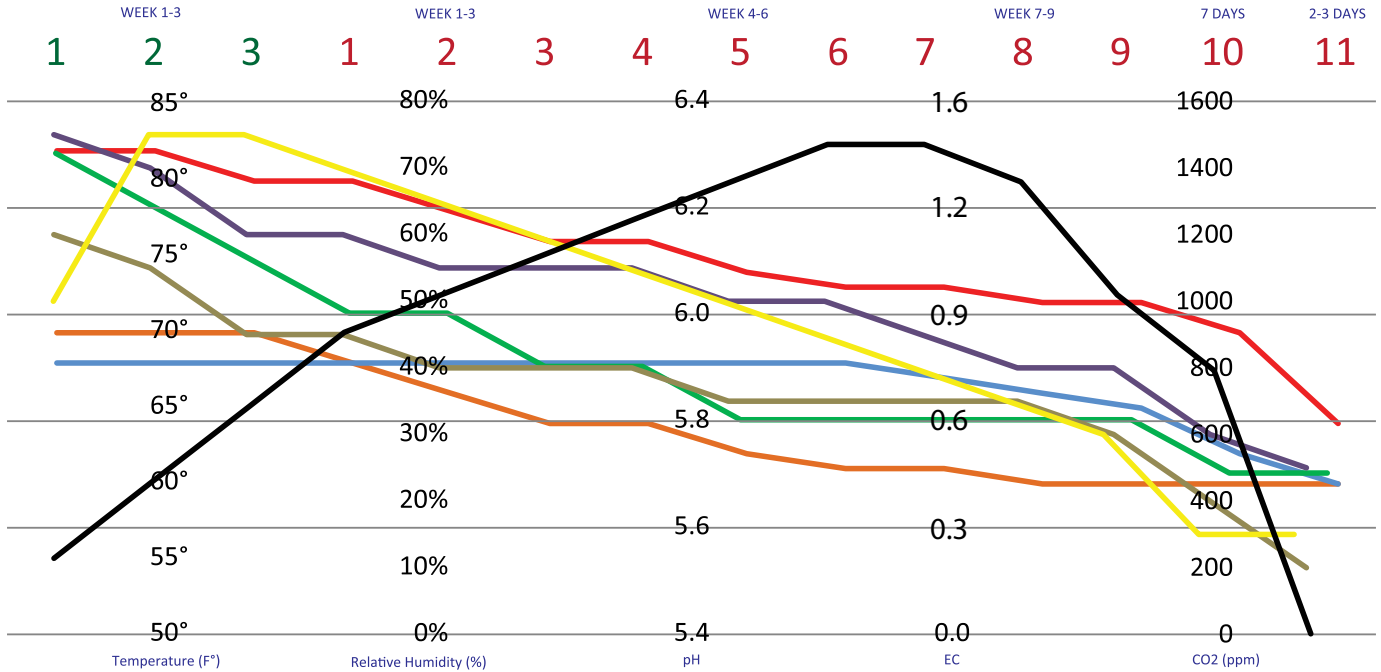

Plant Growth Stage !	Rooted Cutting/Lateral Branchin/Leaf Structure			Flower Set/Formation			Flower Stacking/Building			Flower Maturation/Ripening			Final Ripening	Flush
Weeks !	1	2	3	1	2	3	4	5	6	7	8	9	7 Days	2-3 Days
Day Temp (F°)	82°	82°	80°	80°	78°	76°	76°	74°	73°	73°	72°	72°	70°	64°
Night Temp (F°)	70°	70°	70°	68°	66°	64°	64°	62°	61°	61°	60°	60°	60°	60°
Day Relative Humidity (%)	75%	70%	60%	60%	55%	55%	55%	50%	50%	45%	40%	40%	30%	25%
Night Relative Humidity (%)	60%	55%	45%	45%	40%	40%	40%	35%	35%	35%	35%	30%	20%	0-20%
pH	6.3	6.2	6.1	6.0	6.0	5.9	5.9	5.8	5.8	5.8	5.8	5.8	5.7	5.7
EC	0.2	0.35	0.6	0.65	0.85	1	1.2	1.3	1.4	1.4	1.2	0.9	0.8	0
CO2 (ppm)	1000	1250	1500	1400	1300	1200	1100	1000	900	800	700	600	300	300
Water Temp (F°)	72°	70°	68°	68°	68°	68°	68°	68°	68°	66°	64°	64°	62°	60°

Environmental Considerations: For best results, all aspects of the grow space should be optimized including: day and night temperatures, humidity, light levels, CO2 and air movement. Refer to the CCH20 General Recommendations chart above for specific environmental parameters.

Nutrient Solution Temperature: Maintain nutrient solution temperatures between 66° - 72°. This will allow for the highest levels of dissolved oxygen, discourage proliferation of harmful bacteria and ensure explosive root growth.

Top-Off Reservoir: Use a top-off reservoir to maintain consistent water levels in your hydroponic system. The top-off can be used for nutrient/pH steering or rapid nutrient change outs.

Adjusting pH & EC/ppm: Use one of the following methods for pH and EC/ppm adjustments. Stay within our recommended pH and EC/ppm ranges for each week of veg and bloom.

Method 1 - Add-Back Kit (ABK): Dilute desired add-back concentrates 1 to 10 with water before initiating Add-Back. Close the valve on the ABK slowly. For more information on this method reach out to tech@cch20.com

Method 2 - Top-Off Reservoir: Using a top-off reservoir makes it easy to follow weekly feeding schedules. The top-off reservoir should have a similar nutrient concentration than what's in your hydroponic system or the following weeks nutrient schedule. For best results pH and EC/ppm adjustments should be done through the top-off reservoir.

Method 3 - Nutrient Doser: Use the CCH20 Nutrient Dosing System to automatically manage pH, PPM and ORP levels in your Under Current system.
*When implementing nutrient dosing or fertigation equipment be sure to consult your equipment manufacturer for the proper concentration ratios.

*UC ROOTS can be added directly to the your hydroponic system at recommended rates, it has no negative impact on plants/roots.

Nutrient Change Outs: Full nutrient change outs are beneficial every 7-10 days. If pH levels become unstable or nutrient levels start to rise this may be a good indication to do a full or partial nutrient change out.

CAUTION: Adding organics, sugars, bacteria, and enzyme products have shown to promote biofilms which destabilize pH and require more frequent nutrient change outs.



System Setup

1. Can I integrate a water chiller?
 - a. Yes, refer to Instructions
2. Can I integrate a nutrient auto dosing system?
 - a. Yes. Visit the Automation section on our website for more information.
3. Can I add a top-off reservoir?
 - a. Yes, refer to Using a Top-Off Reservoir. Setup info: refer to Under Current Instructions
4. Can I have my air pump(s) on the floor?
 - a. No
5. Can I have my air pump(s) in the room with supplemented CO₂?
 - a. No
6. Can I run multiple Under Current® systems with one air pump?
 - a. Yes. Contact Us.
7. Can I operate my Epicenter remotely?
 - a. Yes, contact us.

System Operation

1. Is it possible to over-aerate my Under Current?
 - a. Yes
2. Do I need to use Reverse Osmosis (RO) water in my Under Current?
 - a. Yes
3. Should the Air Pump and Water Pump run 24/7?
 - a. Yes
4. How do I find my total system volume?
 - a. Reference the Systems Specifications on the Under Current Products page @ cch2o.com
5. Where should I set my solution level?
 - a. Bare Root: Top of root crown.
 - b. Rockwool/Cube: Just below base of RW/cube 1/4-1/2" below NET POT planting deck.
6. What nutrient solution temperatures are optimal?
 - a. 65-68 degrees F. Refer to General Recommendations for more info.

Grow Media

1. What grow mediums are recommended for use in the Under Current?
 - a. Expanded clay pellets and Growstones
2. Can I use soil or coco in the system?
 - a. No
3. How do I prepare my grow media?
 - a. Refer to manufacturer's recommendations.
4. Can I reuse my grow media?
 - a. Refer to manufacturer's recommendations.

Transplanting

1. Should I transplant sparsely rooted clones into the system?
 - a. No
2. Do I need to top-feed newly transplanted clones?
 - a. No, when clones are well rooted and planted as directed. Refer to Water Level info.
3. Can I move plants from an 8-gallon system to a 13-gallon system?
 - a. Yes
4. Can I veg in the dual/quad lids and transplant to single lids?
 - a. Yes, refer to Veg Guidelines
5. Should I dim/raise my lights after transplanting?
 - a. Yes, generally, for the first 24-48 hrs.

Nutrients & Change Outs

1. What is the best nutrient for the Under Current system?
 - a. Cultured Solutions
2. What is the recommended nutrient strength for the Under Current?
 - a. Refer to the Cultured Solutions feeding schedule
3. How frequently should I change my nutrients?
 - a. Every 7-10 days
4. Should I use Coco Cal (Ca/Mg) in the Under Current?
 - a. Yes, refer to the Cultured Solutions feeding schedule
5. Are Carbohydrates/Sweeteners, Enzymes and Beneficial Bacteria recommended in the Under Current?
 - a. No.

Nutrient Schedules

1. What feeding schedule should I use for my Under Current®?
 - a. Use the High Yield Recirculating Hydro feeding schedule.
2. Can I add weeks to my feeding schedule?
 - a. Yes
 - i. To extend VEG repeat week 4
 - ii. To extend BLOOM repeat week 5
3. At what nutrient strength should I maintain my Mother plants?
 - a. Maintain VEG Week 4 (approx. 325-455PPM) of the High Yield Recirculating Hydro feeding schedule.

pH Adjusting

1. How do I adjust pH?
 - a. Refer to the General Recommendations under Adjusting pH & EC/ppm
2. Can I use both pH UP and pH DOWN if I've overshot my desired pH level?
 - a. No, dilute with water and/or wait at least 24hrs.

Flushing

1. Do I need to flush my system before harvest?
 - a. Yes, refer to the Cultured Solutions feeding schedule
2. Do I need to flush my system between change-outs?
 - a. No

Cleaning

1. Do I need to fully disassemble my system to clean it?
 - a. No
2. What should I use to clean the system?
 - a. Refer to Sanitization Process.
3. Do I have to replace any parts after harvest/cleaning?
 - a. Typically No, when the proper Sanitization Process has been completed.
*Though some growers will replace net pots and air stones as needed.

Plant Maintenance/Trouble Shooting

1. Should I root prune?
 - a. Yes, contact us for more info.
2. If my plants have stalled and haven't grown for weeks, will they recover?
 - a. Possibly, refer to Troubleshooting

System Upgrades & Expansion

1. Can I expand my Under Current system?
 - a. Yes, contact us.
2. Can I upgrade my Water and Air Pump(s)?
 - a. Yes, contact us for more info.



CCH2O WARRANTY

Current Culture H2O Limited 3-Year Warranty

This limited warranty applies only to full systems manufactured at Current Culture H2O in Fresno, CA.

Warranty Includes

- All individual components manufactured by Current Culture H2O come standard with a THREE year limited warranty.
- All Air & Water pumps are covered by their specific manufacturer's warranty. Manufacturer instructions and warranty information booklets are provided with each pump. If any issues with these units covered within their individual warranties should occur, please contact the manufacturer for repair or replacement.

Warranty Excludes

- This limited warranty excludes any components considered to be expendable (i.e. hoses, air diffusers, net pots, seals, etc.). These items should be replaced periodically to ensure proper system functionality.

Warranty Returns & RMA

Current Culture H2O will replace the product, repair the product or send a replacement part or issue a refund (at our option) when the consumer provides a proof of purchase (either a bill of sale, receipted invoice, or other proof that the product is within the warranty period), along with a full description of the defect, to:

Current Culture H2O, 4333 S. Minnewawa Ave #101, Fresno, CA 93725, (559)266-4769, info@cch2o.com

Current Culture H2O reserves the right to request photographic proof of product defect, and request that the defective product in question be shipped to Current Culture H2O to verify the defect or to aid in quality control efforts.

All warranties must be preceded by an authorized RMA form. If a replacement is issued, Current Culture H2O does not cover the cost of shipping replacement items. Customer will be notified of shipping charges for approval and payment information prior to issuing replacement items.

Legal Info

Misuse, or use other than for horticultural purposes is not covered by the limited warranty. In addition, damage caused by: insects, animals or rodents, use of force, incorrect handling, inappropriate use, abuse, neglect, accidents, impact from foreign objects, vandalism, pollutants, set-up on an un-level foundation, alteration, painting, fading, assembly not in accordance with the System Assembly Instructions, or damage caused as a result of storage above the capacity limits of the Product, are not covered by this limited warranty.

This limited warranty does not apply to damage resulting from "acts of nature" such as, but not limited to: wind, hail, storm, tornado, hurricane, heavy snow, ice, blizzard, extreme heat, freezing, flood, fire effects.

This warranty is void if structural parts and/or components not supplied by Current Culture H2O are used.

This warranty does not apply to "Normal Weathering". "Normal Weathering" is defined as exposure to sunlight and extremes of weather and atmosphere, which will cause any colored surface to gradually fade, chalk, or accumulate dirt or stains.

CURRENT CULTURE H2O MAKES NO OTHER WARRANTIES, EXPRESS OR IMPLIED, CONCERNING THE PRODUCT OR THE MERCHANTABILITY OR FITNESS THEREOF FOR ANY PURPOSE. IN NO EVENT SHALL CURRENT CULTURE H2O BE LIABLE FOR INCIDENTAL OR CONSEQUENTIAL DAMAGES. Legal rights vary from state to state, so the above limitations may not apply to you if precluded by local law.

Determination of coverage under this warranty shall be made at the sole discretion of Current Culture H2O.

DISCLAIMER

This system operates by storing and circulating water.

Water is heavy. Water is wet. Water freezes. Water and electricity could lead to electrocution.

It is the responsibility of the user of this system to make sure the surface upon which the system is installed is capable of supporting SUBSTANTIAL weight and is waterproof, and that all electrical components are install so that they will not get wet.

Current Culture H2O will NOT be responsible for any damage caused by improper installation or consequential damage to person or property caused by the use of this product even if it is determined to be defective.

Please take these warnings into consideration when planning your installation.

Copyright © 2018 Current Culture H2O. All Rights Reserved.