

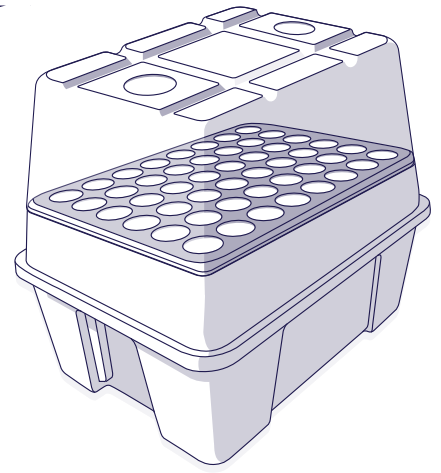

CLONE STATION 48

INSTRUCTION MANUAL



HOW TO ASSEMBLE YOUR PLANT CLONING MACHINE

- 1 Except for the water pump and sprayer manifold, rinse all parts in lukewarm water.
- 2 The orientation of the red sprayers is factory set for better spraying coverage (**Figure A**). If you feel that customization of the spray pattern is required; simply rotate the red sprayers as required.
- 3 Carefully fit the water pump onto spray manifold. To prevent breaking the manifold tube, avoid using excessive force.
- 4 Use the pump suction cups to adhere the pump to the base of the tub.
- 5 There is a mark in the centre of the tub base; place the pump into position as shown in **Figure B** (note the position of the power cord). Feed the power cord through the slot in the rim on the short side of the tub.
- 6 For a correct fit, place the lid on the base as per **Figure C**, ensuring that it is watertight.
- 7 Before putting clones into the system, fill with water to a level just under the red sprayers in the tub, then place the lid back on. Turn on the machine to rinse all internal parts. Run for at least 5 minutes, then discard and replace the water. Repeat this procedure.

FIGURE A

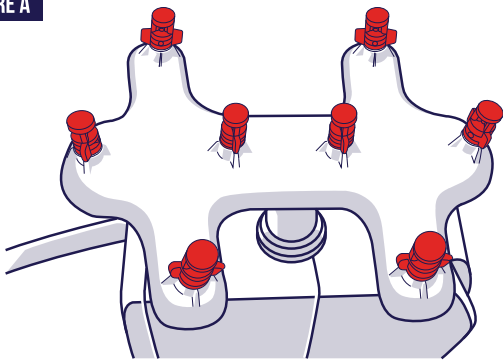

FIGURE B

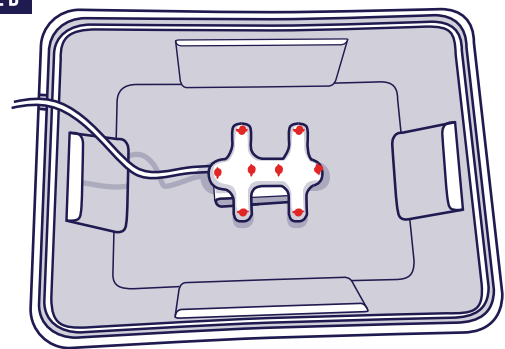
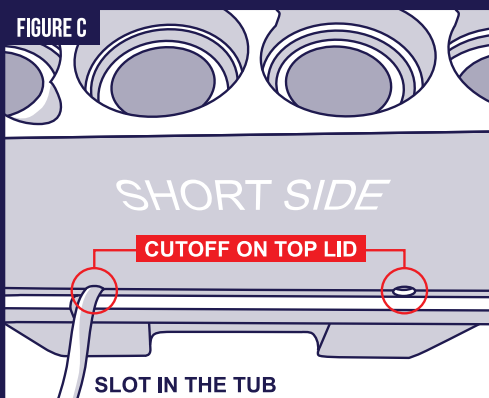

FIGURE C



PLEASE
DOUBLE CHECK
YOUR
ASSEMBLY TO
ENSURE IT IS
THE SAME AS
FIGURE C
BEFORE USING
THE PRODUCT

FIGURE D

When ready,
place clear
humidity
dome on top
of unit and
adjust air
vents
accordingly.

